

FLOWING EXPERTISE

BACKFLOW PREVENTION DEVICES





FLOWING EXPERTISE

With our heating and plumbing solutions, we have been redesigning the comfort of the spaces we live and work in for over 60 years. This is thanks to the flow of expertise, technology, experience and innovations that we have acquired over the years by constantly exchanging ideas with our customers and suppliers. A flow that pushes boundaries, allowing us to constantly set the benchmark. A flow that allows us to always look one step ahead into the future.



FLOW OF LIFE

A unique way of flowing. It is **continuous change**, a high degree of reliability in our work, and the ongoing pursuit of total quality, which is the result of small everyday actions.



FUTURE

Innovation aimed at creating **new forms of comfort** for spaces, which motivates us to continue to grow and improve.



SUSTAINABILITY

Our focus on preserving **environmental, social and economic well-being** so that it can be passed on to future generations through our products and processes.



TECHNOLOGY

Our ability to do research, invest in processes and develop **state-of-the-art solutions** in an ever-evolving world of expertise.



MADE IN CALEFFI

A uniqueness consisting of many details, which is what we are known for worldwide. True **"Made in Italy"** quality, the hallmark of our company.



HISTORIC BRAND

With over 60 years' experience in the industry, we have been included in the special register of historic brands of national interest.

We are proud of our place in Italian history.

T R A I N I N G

We have always invested in customer training and contributed to boosting know-how within the sector. CALEFFI EXPERIENCE is the result of this commitment, acting as a single umbrella under which a long list of training activities are brought into effect. First there was the wealth of technical documentation (including this brochure), and then came digital with product videos, constantly updated websites, Coffee with Caleffi webinars, apps, BIM libraries and 3D viewers.



SUBSCRIBE TO OUR FREE COFFEE
WITH CALEFFI SESSIONS



FOLLOW OUR YOUTUBE CHANNEL



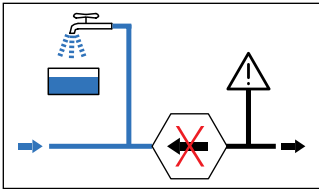

This Monographic Guide concerns the problem of pollution of water supplies from backflow and presents the range of Caleffi products specifically designed to prevent this problem.

The materials of the components and their performance characteristics meet the specific regulatory and safety requirements of water supply systems.

POLLUTION OF WATER SUPPLIES - NORMATIVE REFERENCES

This Monographic Guide addresses the following topics:

- 1) pollution of water supply systems and the relative reference standards for its prevention;
- 2) classification and selection of backflow prevention devices according to the type of system and the medium present in downstream system;
- 3) examples of system layouts with indication of points requiring protection using suitable pollution prevention devices;
- 4) presentation of Caleffi products with information on installation, maintenance and functional testing.

Pollution is defined as any relative degradation of the quality of potable water.

European standard **EN 1717:2000** "Protection against pollution of potable water in water installations and general requirements of devices to prevent pollution by backflow" is the reference point as regards the prevention of pollution of public water supplies caused by the backflow of medium from private systems downstream.

The above standard is applied in conjunction with the **EN 806:2012** series of standards, "Specifications for installations inside buildings conveying water for human consumption" that indicate the requirements for design, operation and maintenance.

Both these European reference standards should be applied in conjunction with the applicable national standards and regulations. Installations must be designed and maintained in such a way that they do not cause contamination of the public water supply or of the internal system by backflow of any type of substance considered hazardous.

The standard **EN 1717** classifies the water contained in installations into five categories according to the degree of risk they pose to human health; these categories range from 1, with no human health hazard, to 5, the most hazardous.

Category 1:

Water to be used for human consumption coming directly from a potable water distribution system.

Category 2:

Medium presenting no human health hazard, as per 1, the quality of which can have undergone a change in taste, odour, colour or temperature.

Category 3:

Medium presenting some human health hazard due to the presence of one or more harmful substances.

Category 4:

Medium presenting a human health hazard due to the presence of one or more "toxic" or "very toxic" substances or one or more radioactive, mutagenic or carcinogenic substances.

Category 5:

Medium presenting a human health hazard due to the presence of microbiological or viral elements.

According to this classification, suitable backflow prevention devices must be fitted in water distribution circuits.

EN 1717 lists the operating principle and minimum requirements of devices designed to protect the public water supply from the backflow of fluids belonging to one of these five categories.

Protection devices are grouped in eight Families, identified by the letters A, B, C, D, E, G, H, L, each of which may have one or more variants called Types, also identified with the letters A, B, C, or D. EN 1717 specifies for each Type of device the minimum and maximum medium category and the conditions in which it may be

used for to protect the installation against backflow.

The sequence of appliances, including protection device, filters, check valves, shut-off valves, pressure test ports, air gaps, etc. that together comprise the backflow protection, is known as the **Protection Unit**. The Protection Point is defined as the point in the system in which the Protection Unit is applied.

The generic symbol used in EN 1717 to identify the Protection Unit is a hexagon containing the letters indicating the protection Family and Type, as shown in the following figure:



Here below are some examples of Protection Units with the relative sequences of devices required by EN 1717.

Protection unit: Family B, Type A

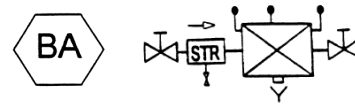

Protection unit: Family C, Type Aa

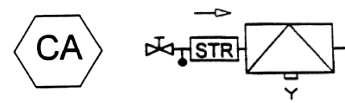

Protection unit: Family E, Type A

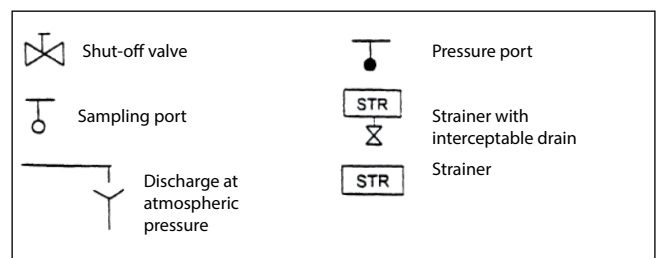
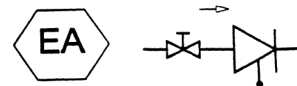

The indications in EN 1717 may be applied to all domestic, industrial/commercial and non domestic installations connected to the public potable water supply:

- domestic installations in residential or similar buildings, such as homes, hotels, schools, offices, hostels, etc.: kitchen sinks, hand basins, baths, showers, WCs, domestic hot water systems, domestic washing machines and dishwashers, bidets, garden irrigation systems, systems with low concentrations of additives that are not harmful to human health, such as water treatment, air-conditioning systems, etc.;
- in industrial and commercial installations the standard applies to all applications of potable water with similar use to a domestic installation, excluding therefore process water; also fire fighting, centralised heating or irrigation systems;
- non domestic installations for professional uses of water, for example, industries, commerce, agriculture, clinics, public and private swimming pools and thermal baths.

EN 1717 is used as the main reference in the preparation of the relative product standards, or is used directly in the absence of specific product standards.

POLLUTION OF WATER SUPPLIES - NORMATIVE REFERENCES

Backflow

Potable water from the mains supply may be subject to pollution caused mainly by the contaminated medium flowing back from plumbing installations connected directly to the mains supply. Backflow can be attributed to a variation in the pressure difference that causes a consequent inversion of the normal direction of flow at certain point of the installation. This phenomenon, termed "back flow", occurs when:

- the pressure in the mains system is less than that in the plumbing circuit receiving the supply (back syphonage). This situation can occur, for example, due to a break in the pipework of the mains supply and the consequent maintenance work, or when significant quantities of water are drawn by other users connected upstream, such as fire-fighting systems.
- the pressure in the plumbing circuit receiving the supply rises (counter pressure) due, for example, to water being pumped from a well.

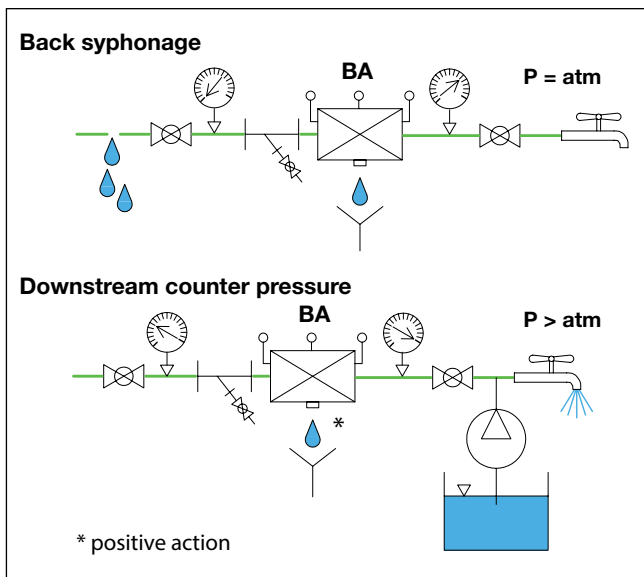

Risk assessment

Given the potential dangers of the phenomenon and the requirements of current legislation, a risk assessment of backflow pollution must be carried out on the basis of the type of system and the characteristics of the medium that flows inside it. A suitable backflow prevention device must be selected on the basis of the assessment performed by the system designer and the mains supplier. The device must be located along the internal distribution system at the points at risk of backflow which would be hazardous to human health. In addition to consultation of the European standard EN 1717, it is always necessary to consult the water supplier and the specific national regulations as, depending the type of installation, there may be more restrictive or more permissive derogations from the European standard. In situations where there are mediums present that pose different degrees of hazard, backflow prevention should consider the most hazardous of these mediums. In the case of mediums that are exceptionally hazardous, it will be necessary to assess additional technical parameters. In the case of applications where it is not possible to verify the risk level, it is necessary to hypothesise the greatest risk. The "Protection Matrix" tables reported in the following pages list various types of installation and the corresponding medium categories.

Protection Unit - Product standards - Caleffi devices

Tables 1 and 2 below list all the Protection Units defined in EN 1717, with the relative medium categories, the product standards and the corresponding products in the Caleffi catalogue.

Devices	Category	Authorised level of the Protection Unit
Tap with spray head over washbasins, sinks, showers, baths; excluding WCs and bidets	5	Protection unit for category 2 and EB, ED, HC
Tub with water inlet below the rim of the tub (b)	5	Protection unit for category 3
Rubber hose attachment outlet (a b)	5	Protection unit for category 3
Overground or in-ground irrigation (b)	5	Protection unit for category 4

(a) Used for washing, cleaning or garden irrigation
 (b) The Protection Unit must be installed above the maximum operating level



Family Type	Protection unit EN 1717	Mediums category					Product standard	Caleffi series
		1	2	3	4	5		
AA	Unrestricted backflow preventers	*	●	●	●	●	EN 13076	
AB	Backflow preventers with non-circular overflow (unrestricted)	*	●	●	●	●	EN 13077	
AC	Backflow preventers with submerged inlet comprising an air inlet and overflow	*	●	●	-	-	EN 13078	
AD	Backflow preventers with injector	*	●	●	●	●	EN 13079	
AF	Air gap with circular overflow (restricted)	*	●	●	●	-	EN 14622	
AG	Air gap with minimum circular overflow (verifiable by test or measurement)	*	●	●	-	-	EN 14623	
BA	Verifiable backflow preventers with reduced pressure zone	●	●	●	●	-	EN 12729	580, 574, 575
CA	Non-verifiable backflow preventers with different pressure zones	●	●	●	-	-	EN 14367	573
DA	In-line anti-vacuum valves from DN 8 to DN 80	○	○	○	-	-	EN 14451	
DB	Pipe interrupter with atmospheric vent and moving element from DN 10 to DN 20	○	○	○	○	-	EN 14452	
DC	Pipe interrupter with permanent atmospheric vent from DN 10 to DN 20	○	○	○	○	○	EN 14453	
EA	Controllable anti-pollution check valves from DN 6 to DN 250	●	●	-	-	-	EN 13959	3045, 3046
EB	Non-controllable anti-pollution check valves from DN 6 to DN 250			■			EN 13959	3047
EC	Controllable anti-pollution double check valves from DN 6 to DN 250	●	●	-	-	-	EN 13959	
ED	Non-controllable anti-pollution double check valves from DN 6 to DN 250			■			EN 13959	
GA	Direct controlled mechanical backflow preventer	●	●	●	-	-	EN 13433*	
GB	Hydraulically controlled mechanical backflow preventer	●	●	●	●	-	EN 13434*	
HA	Vacuum breaker with pipe fitting from DN 15 to DN 32	●	●	○	-	-	EN 14454	
HB	Anti-vacuum valves with pipe fitting from DN 15 to DN 25 inclusive	○	○	-	-	-	EN 15096	
HC	Automatic diverter			■			EN 14506	
HD	Anti-vacuum valves with pipe fitting from DN 15 to DN 25 inclusive	●	●	○	-	-	EN 15096	
LA	Pressurised air inlet valves from DN 15 to DN 50	○	○	-	-	-	EN 14455	
LB	Pressurised air inlet valves from DN 15 to DN 50	●	●	○	-	-	EN 14455	

Units with atmospheric discharge must not be installed in zones at risk of flooding (for example, AA, BA, CA, GA, GB...)





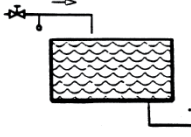
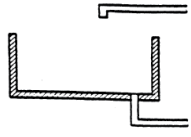
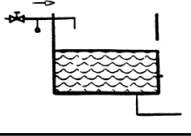
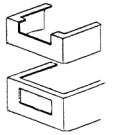
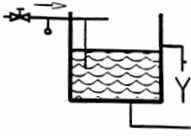
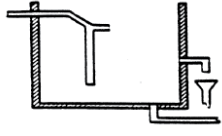
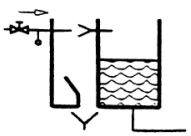
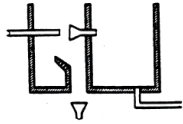
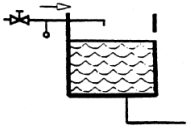
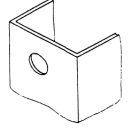
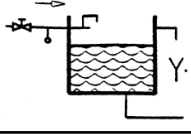
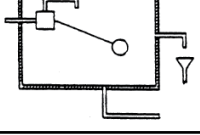
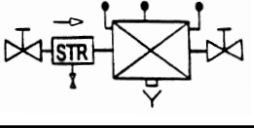
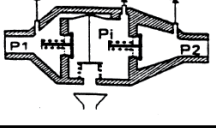
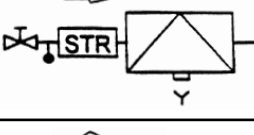
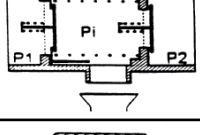
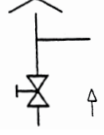
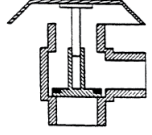
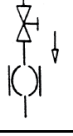
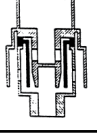

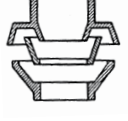
● Covers the risk ○ Covers the risk only if p = atm - Does not cover the risk * Not applicable ■ Only for certain domestic uses (see Table 2) * Not confirmed

POLLUTION OF WATER SUPPLIES - NORMATIVE REFERENCES

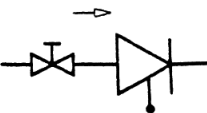
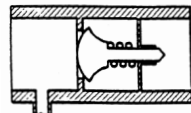
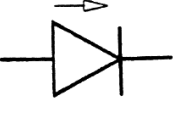
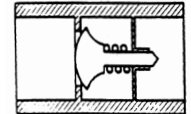
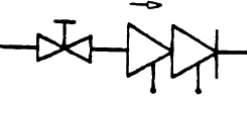
The following table presents the graphic symbols of the Protection Units and the design principles of the devices listed by EN 1717.

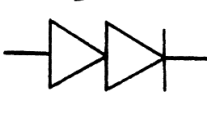
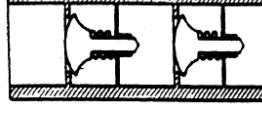
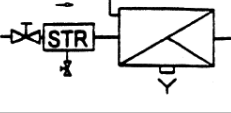
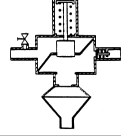
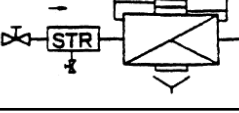
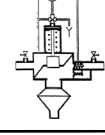
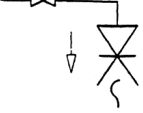
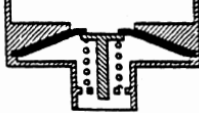
Family Type	Protection unit EN 1717	Protection unit: graphic symbol	Design principle
AA	Unrestricted backflow preventers		
AB	Backflow preventers with non-circular overflow (unrestricted)		
AC	Backflow preventers with submerged inlet comprising an air inlet and overflow		
AD	Backflow preventers with injector		
AF	Air gap with circular overflow (restricted)		
AG	Air gap with minimum circular overflow (verifiable by test or measurement)		
BA	Verifiable backflow preventers with reduced pressure zone		
CA	Non-verifiable backflow preventers with different pressure zones		
DA	In-line anti-vacuum valves from DN 8 to DN 80		
DB	Pipe interrupter with atmospheric vent and moving element from DN 10 to DN 20		
DC	Pipe interrupter with permanent atmospheric vent from DN 10 to DN 20		

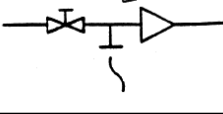
POLLUTION OF WATER SUPPLIES - NORMATIVE REFERENCES

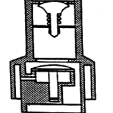
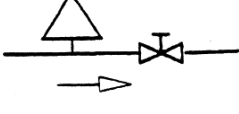
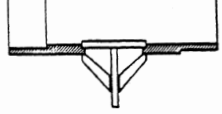
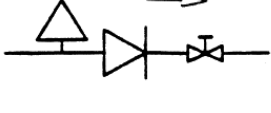
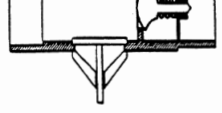
EA	Controllable anti-pollution check valves from DN 6 to DN 250		
EB	Non-controllable anti-pollution check valves from DN 6 to DN 250		
EC	Controllable anti-pollution double check valves from DN 6 to DN 250		
ED	Non-controllable anti-pollution double check valves from DN 6 to DN 250		
GA	Direct controlled mechanical backflow preventer		
GB	Hydraulically controlled mechanical backflow preventer		
HA	Vacuum breaker with pipe fitting from DN 15 to DN 32		
HB	Anti-vacuum valves with pipe fitting from DN 15 to DN 25 inclusive		
HC	Automatic diverter		
HD	Anti-vacuum valves with pipe fitting from DN 15 to DN 25 inclusive		
LA	Pressurised air inlet valves from DN 15 to DN 50		
LB	Pressurised air inlet valves from DN 15 to DN 50		

PROTECTION MATRIX

The following table, the "Protection Matrix", lists a series of installations arranged according to type. For each installation type, the table indicates the risk category of the medium contained. The categories range from 2 to 5 according the hazard posed to human health, as defined in EN 1717. The table has been drawn up on the basis of the indications provided by European standard EN 1717 and national regulations. The table is not comprehensive, and checks should be conducted at the time of application to ensure compliance with any local standards or regulations. Some installations are represented in the diagrams on the following pages.

Type of installation	Medium category			
	2	3	4	5
General				
Hot and cold water mixing devices in domestic water systems (see diagrams n° 1, 2, 3 and 4)	x			
Water cooling devices for air conditioning units, without additives	x			
Filling of heating systems, without additives (see diagrams n° 10, 11 and 12)		x		
Filling of heating systems, with additives (see diagram n° 13)			x	
WC: filling of tank with float			x	
Filling of forced circulation solar thermal systems			x	
Domestic water softeners regenerated with common salt	x			
Commercial water softeners (only regenerated with common salt) (see diagram n° 15)		x		
Filling of closed circuits with dosing devices for additives such as softeners or demineralisers (see diagram n° 14)			x	
Toilet cleaning systems with chemicals and disinfectants			x	
Bathtub filling and cleaning system with water outlet below the edge of the tub (immersed)			x	
Hand held showers for baths or sinks (see diagram n° 6)				x
Filling of swimming pools			x	
Hairdressers' shampoo basins			x	
Pillar taps (not mixer taps) for sinks, washbasins, bidets	x			
Sprinkler fire fighting systems with antifreeze solutions (see diagram n° 23)			x	
Water in sinks, baths and showers (see diagram n° 5)				x
Domestic dishwashers and washing machines (see diagram n° 17)		x		
Industrial tanks				x

Type of installation	Medium category			
	2	3	4	5
Taps for non domestic applications with connection pipe				x
Permeable pipes not for garden use, laid underground or on the ground with or without chemical additives				x
Reclassified water systems				x
Urinals, WCs and bidets (see diagrams n° 7, 8 and 9)				x
Domestic or residential gardens				
Hand-held fertiliser sprayers for use in domestic gardens		x		
Mini-irrigation systems, without fertilisers or insecticides, such as automatic sprinklers or porous pipes (see diagram n° 31)				x
Taps with hose connections			x	
Food processes				
Dairies			x	
Food preparation			x	
Butchers and meat suppliers				x
Abattoirs				x
Vegetable washing (see diagram n° 21)				x
Agriculture				
Boot washing systems for access to protected environments (see diagram n° 24)			x	
Milking machines, cleaning machine with addition of disinfectant (see diagram n° 20)				x
Commercial irrigation with outlets underground or at ground level and/or permeable pipes, with or without chemical additives				x
Commercial hydroponic systems				x
Insecticide or fertiliser application systems				x

PROTECTION MATRIX

Type of installation	Medium category			
	2	3	4	5
Catering				
Dish-washing machines in commercial buildings (see diagram n° 18)			x	
Bottle washing equipment (see diagram n° 19)				x
Automatic dispensers without injection of ingredients or CO2	x			
Beverage distributors in which the ingredients or CO2 are injected in the inlet or distribution pipe (see diagram n° 22)			x	
Refrigeration appliances			x	
Machines for washing beer tanks			x	
Appliances for cleaning pipes that convey beverages in restaurants			x	
Connections with mobile structures of stands and recreational areas (see diagram n° 25)			x	
Ice-making machines	x			
Large kitchen machines with automatic filling systems	x			
Dish-washing machines in hospitals				x
Breweries and distillers			x	
Industrial and commercial applications				
Car washing and degreasing systems (see diagram n° 26)			x	
Commercial laundries			x	
Dry-cleaning appliances			x	
Printing and photographic appliances			x	
Water treatment or softening systems that use products other than salt			x	
Washing/disinfecting systems with injection of detergents			x	
Humidifying appliances			x	
Dosing devices with cat. 4 mediums for non-potable applications			x	
Treatment with inverse osmosis (see diagram n° 16)			x	
Pressure washers (see diagram n° 27)			x	
Fire fighting systems using pressurised water			x	
Sterilizers/disinfection systems for materials packaging			x	
Sterilizers for carcinogenic material			x	

Type of installation	Medium category			
	2	3	4	5
Water with disinfection not for human use			x	
Drain cleaning systems				x
Industrial and chemical systems				x
Laboratories				x
Mobile tank and sewer emptying systems				x
Water collection systems for non-agricultural uses (see diagram n° 30)				x
Drinking systems for animals (see diagram n° 29)				x
Water collection systems for fire fighting applications				x
Medical				
Disinfecting systems			x	
X ray machines, cooling appliances			x	
Domestic dialysis machines		x		
Medical or dentistry appliances with under head inlet (see diagram n° 28)				x
Bed pan washing systems				x
Clothes washing systems in hospitals				x
Domestic appliances such as washtubs, sinks and hand basins				x
Hospital dialysis machines				x
Laboratories				x
Mortuary appliances				x

SYSTEM DIAGRAMS

1. Hot and cold water mixing devices in domestic water systems (cat. 2) with recirculation circuits

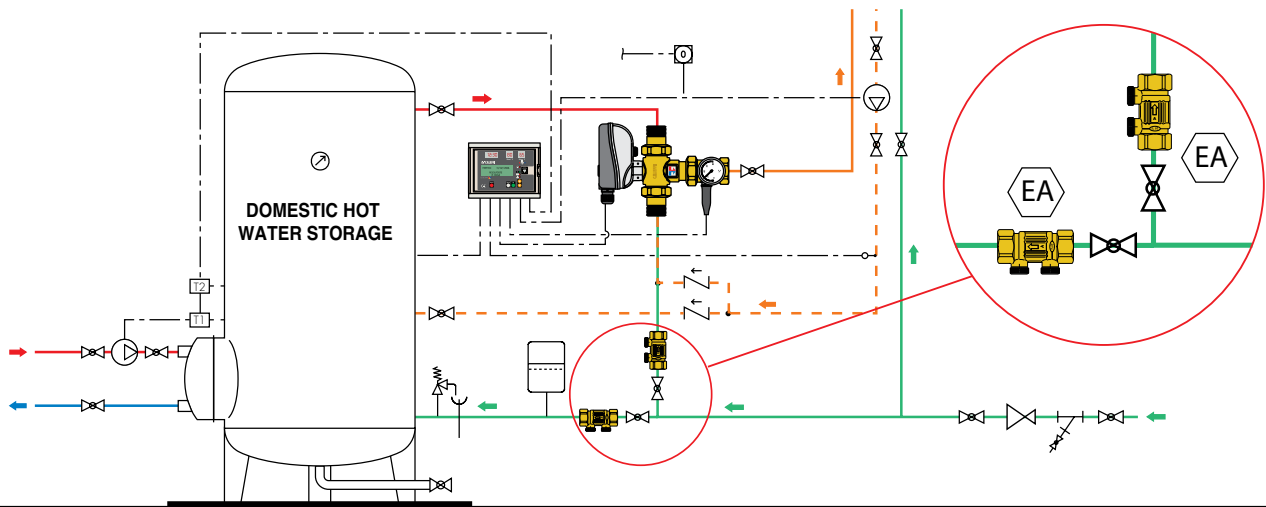

2. Hot and cold water mixing devices in domestic water systems (cat. 2) without recirculation circuits

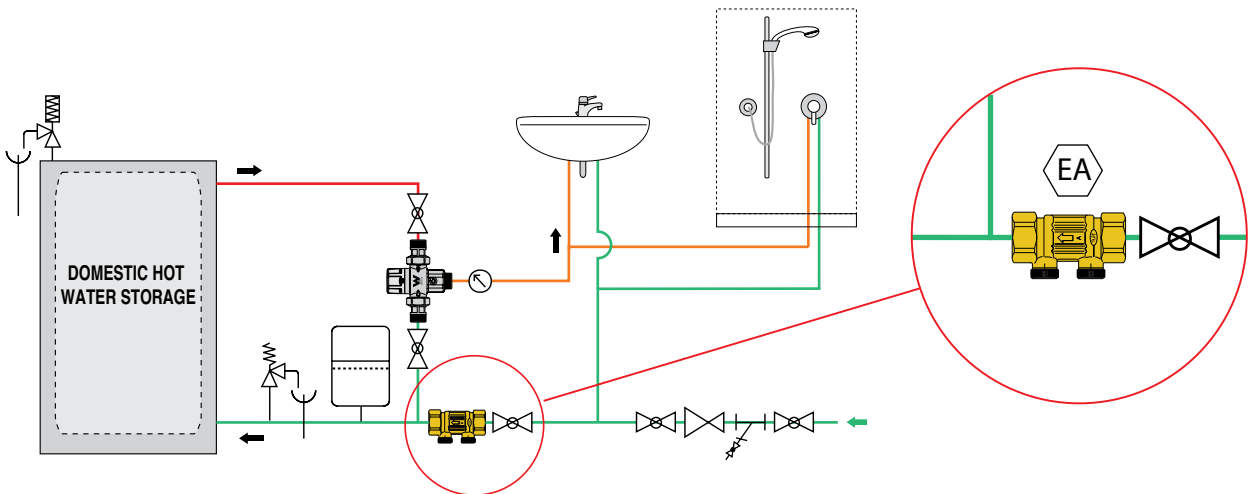

3. Hot and cold water mixing devices in domestic water systems (cat. 2), application at point of use

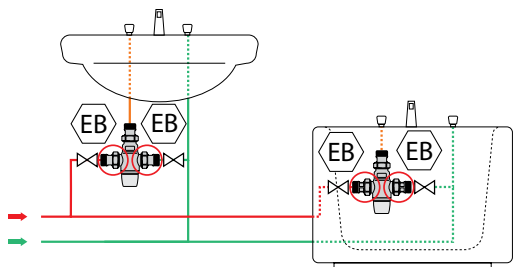

4. Pressure boosting stations (cat. 2)

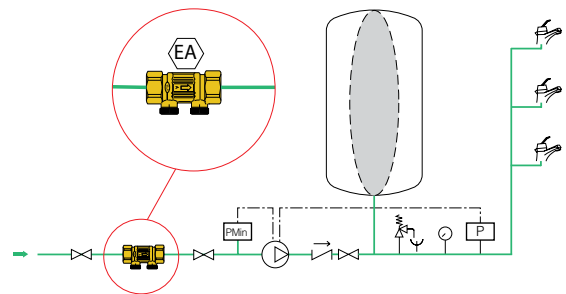

5. Domestic hot and cold water systems (cat. 2)

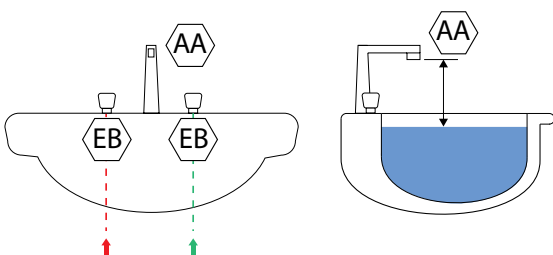

6. Hand-held shower connected to taps of baths or basins, excluding WCs and bidets (cat. 5)

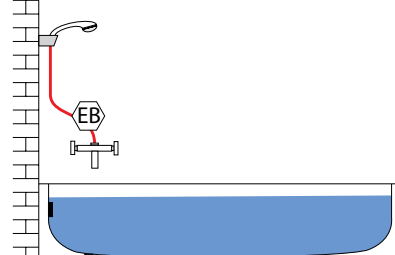

SYSTEM DIAGRAMS

7. WC and urinal rinsing systems with addition of detergents (cat. 5)

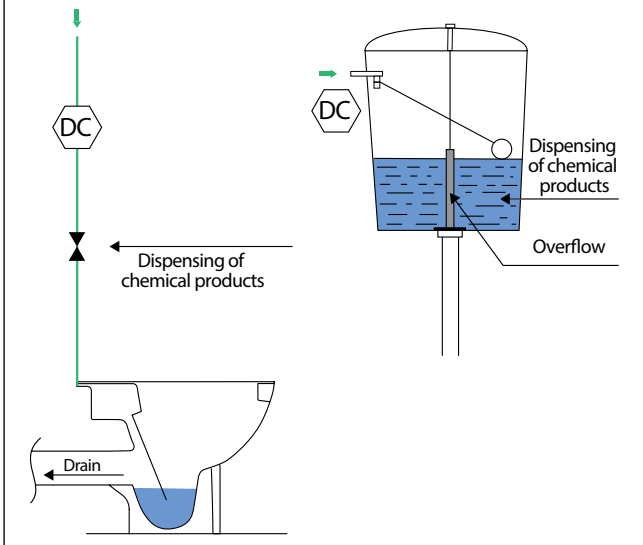

8. Hand-held spray from WCs and bidets (cat. 5)

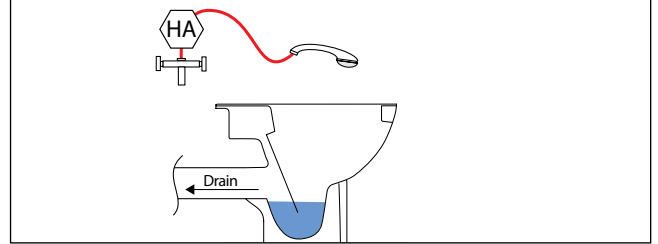

9. Bidet with mixer tap (cat. 5)

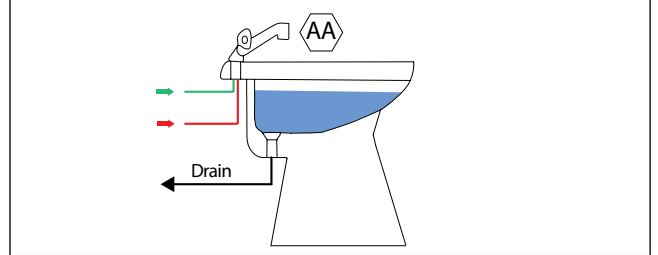

10. Filling of heating systems, without additives (cat. 3)

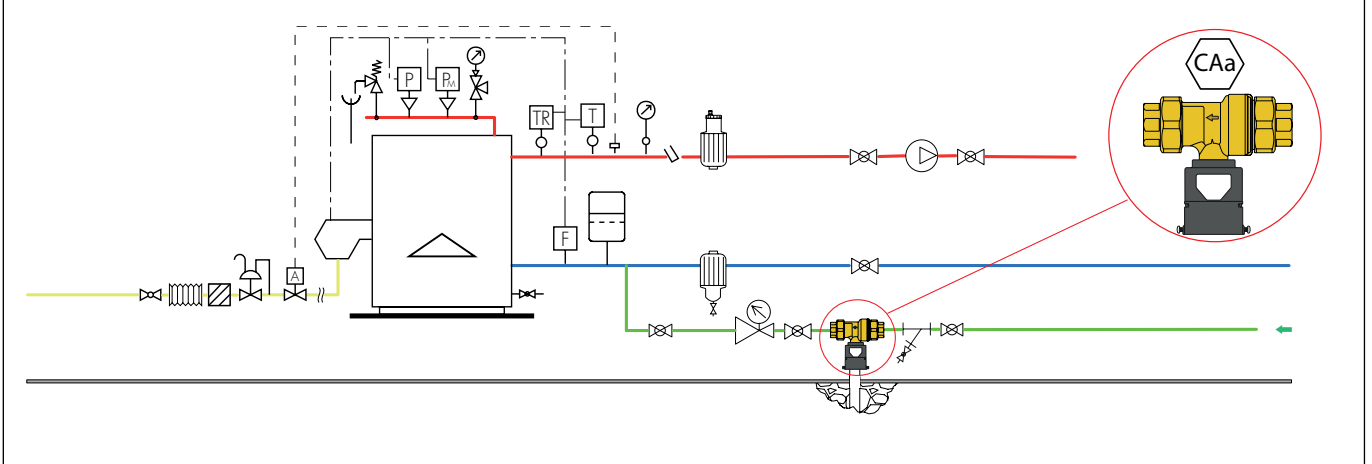

11. Filling of wall-mounted boilers for heating only or heating and DHW without additives (cat. 3)

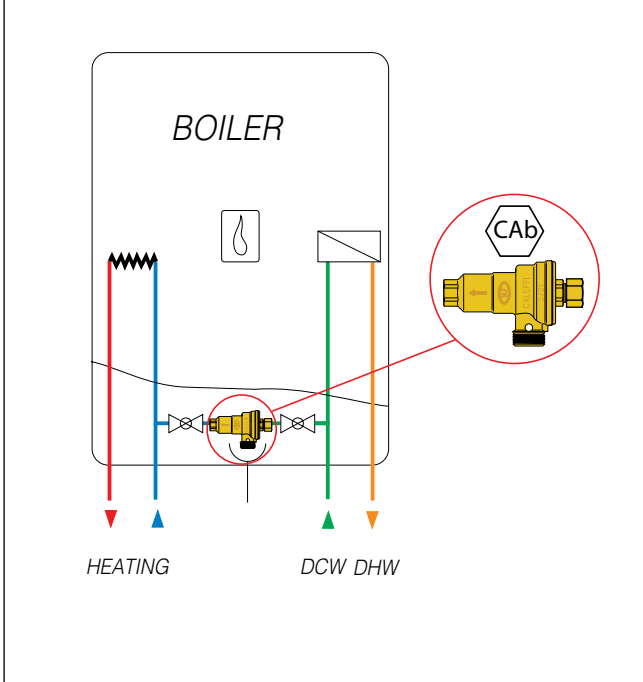

12. Filling of heating circuit with separate water for Heat Interface Unit (cat. 3)

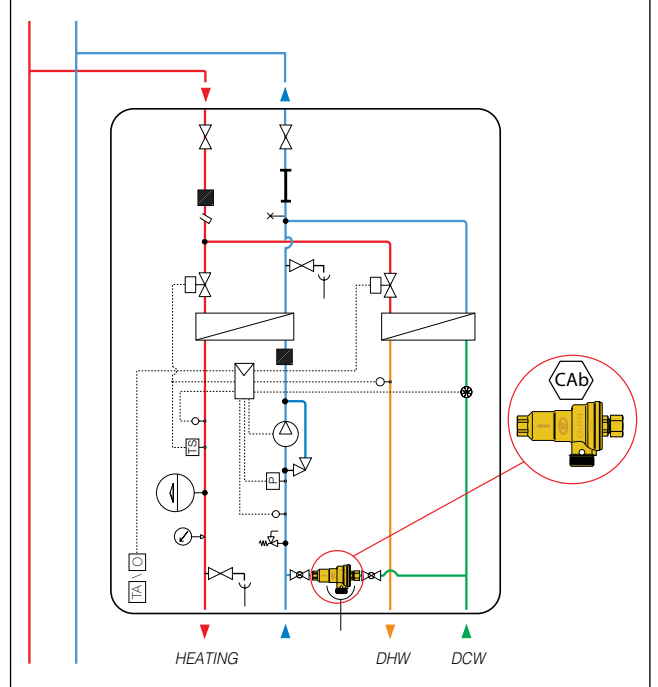

SYSTEM DIAGRAMS

13. Filling of heating systems, with additives (cat. 4)

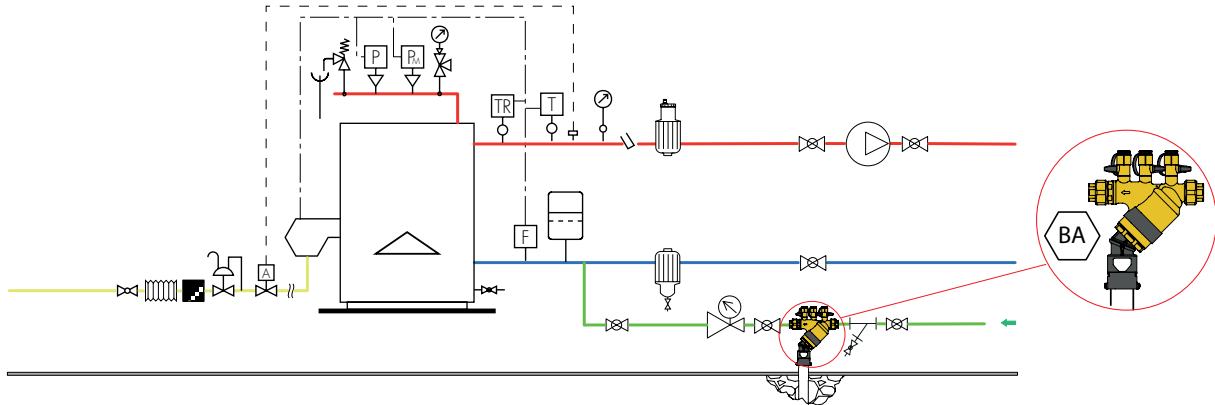

14. Filling of closed circuits with dosing devices for additives such as softeners or demineralizers (cat. 4)

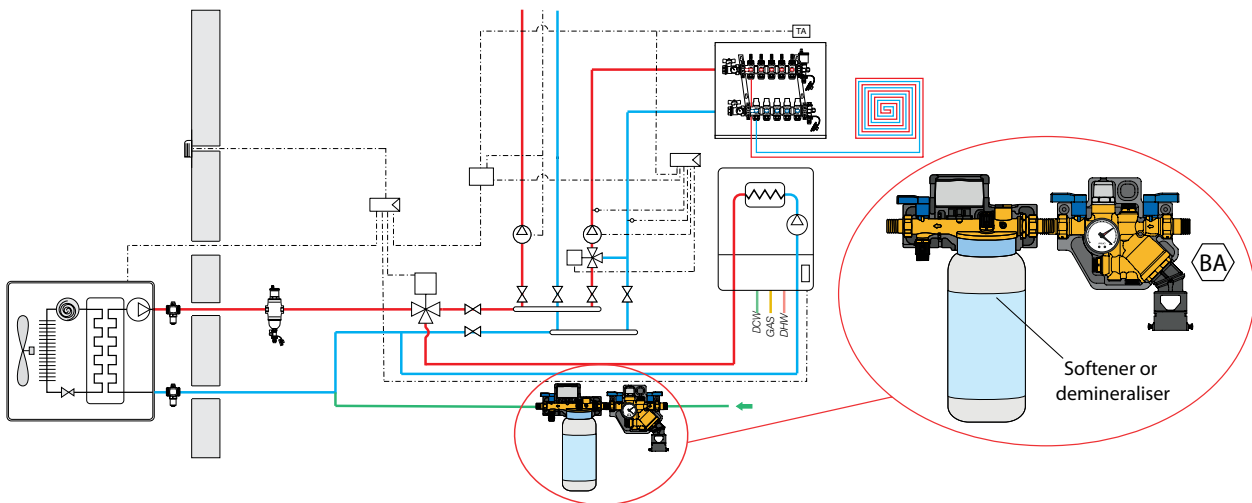

15. Commercial water softeners (with common salt regeneration only) (cat. 3)

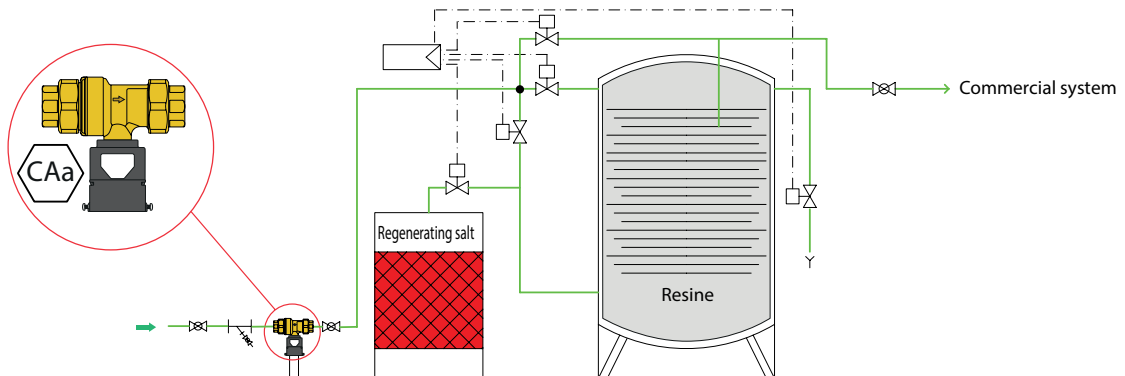

16. Reverse osmosis water treatment system: system with recirculation and chemical product dosing (cat. 3 or 4)

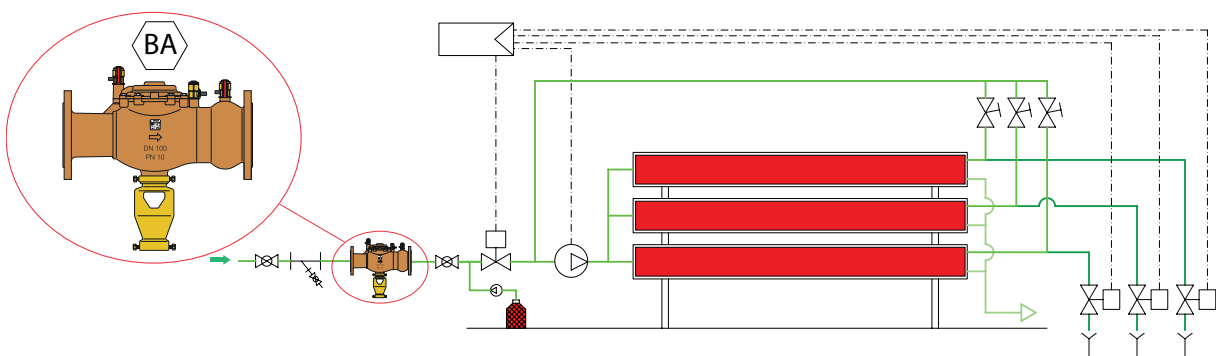

SYSTEM DIAGRAMS

17. Domestic dishwashers and washing machines (cat. 3)

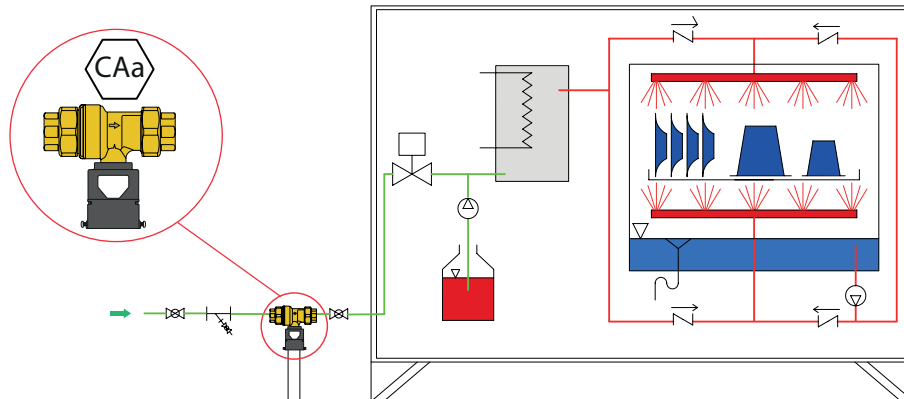

18. Dishwashing machines in commercial buildings (cat. 4)

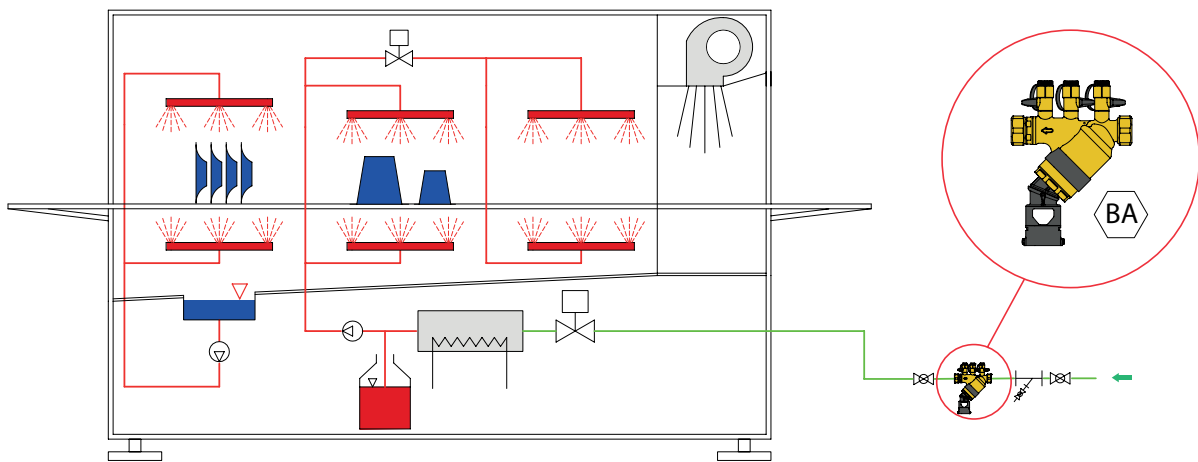

19. Bottle washing equipment (cat. 5)

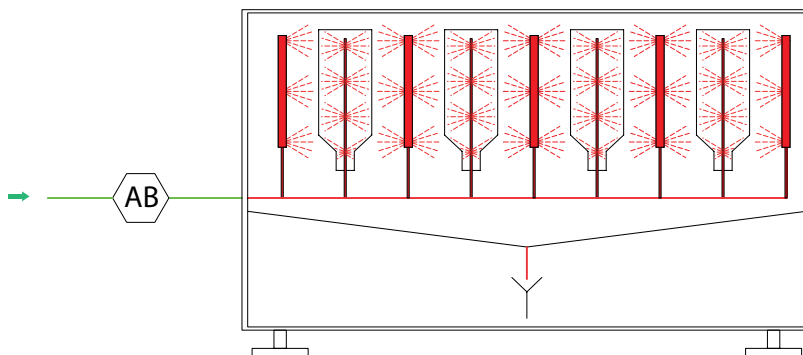

20. Milk tank washing systems (cat. 5)

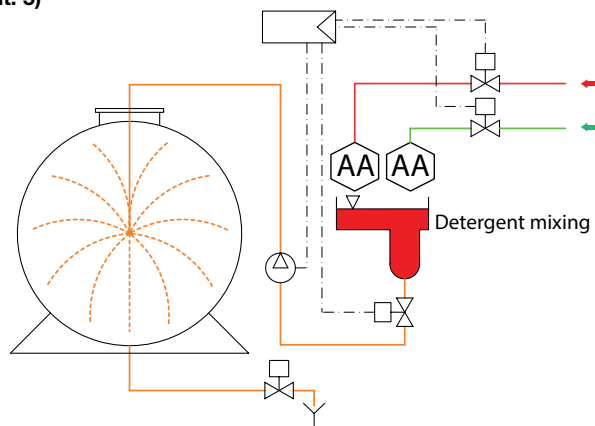

SYSTEM DIAGRAMS

21. Food preparation machines, potato peelers (cat. 5)

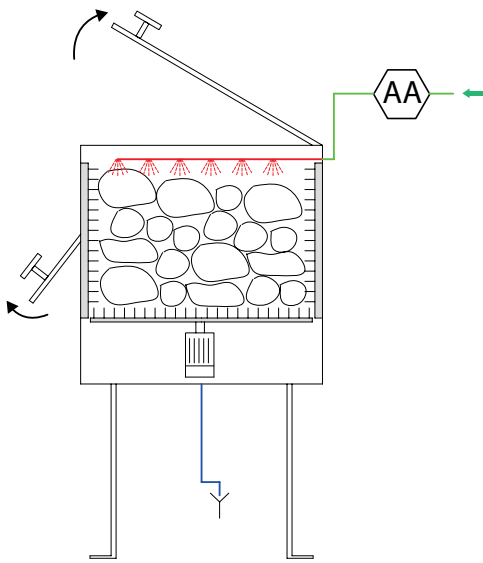

22. Automatic hot drink dispensers (cat. 4)

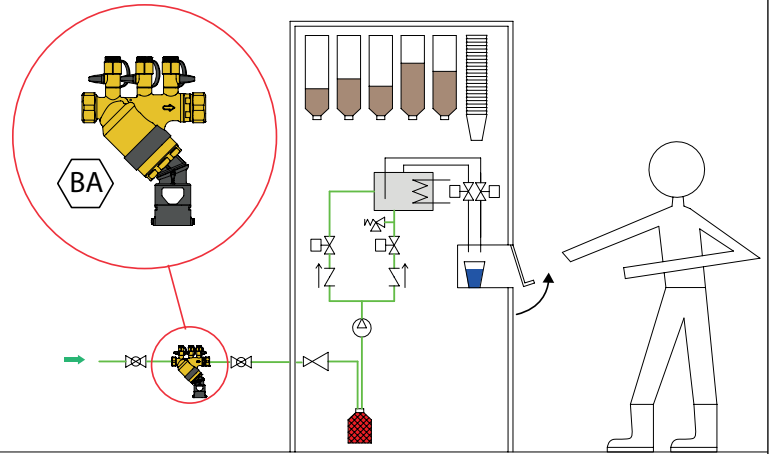

23. Sprinkler fire fighting systems with antifreeze solutions (cat. 4)

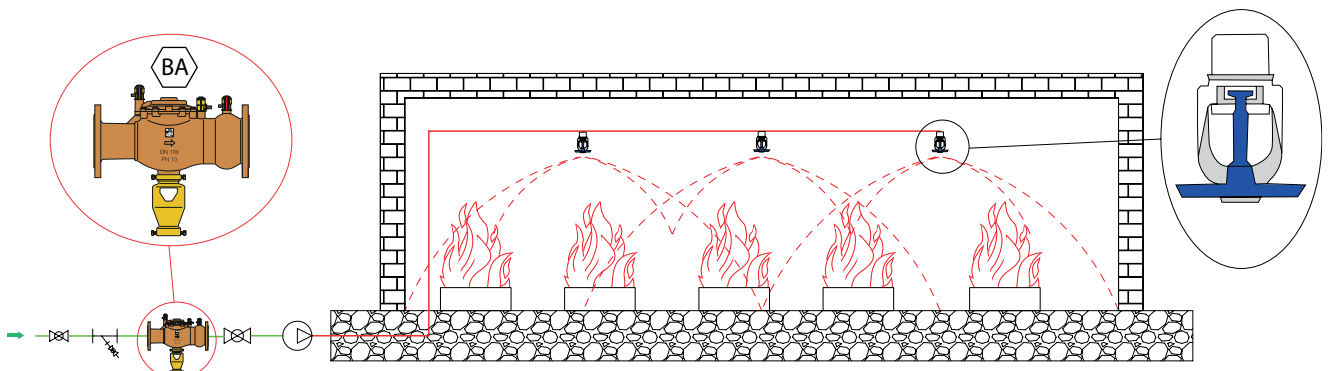

24. Boot washing systems for access to protected environments (cat. 4)

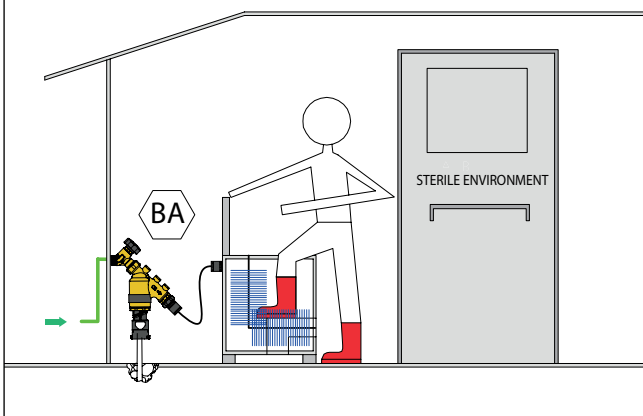

25. Connections with mobile structures of stands and recreational areas (cat. 4)

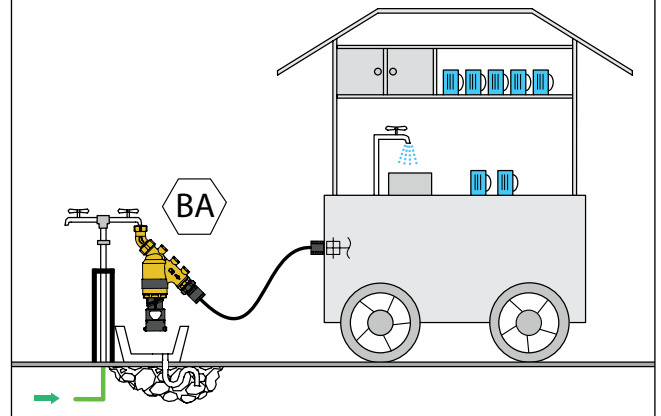

SYSTEM DIAGRAMS

26. Car washing and degreasing systems without recirculation (cat. 4)

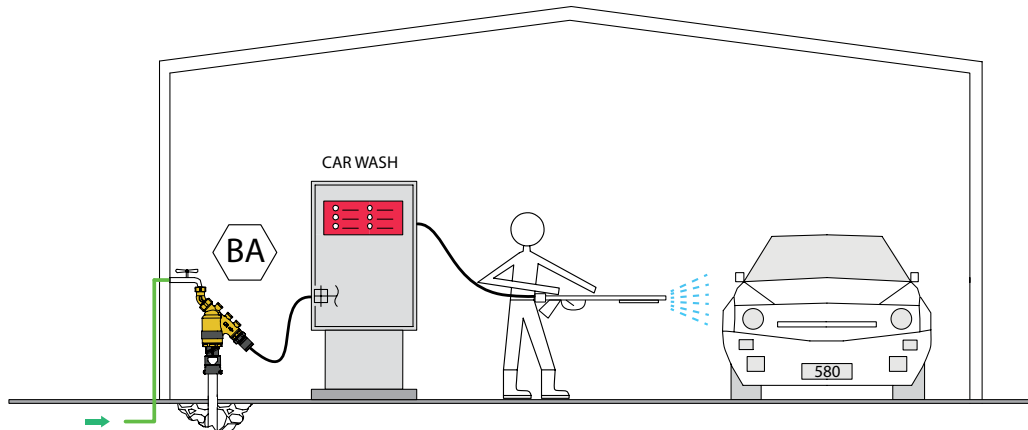

27. Pressure washers (cat. 4)

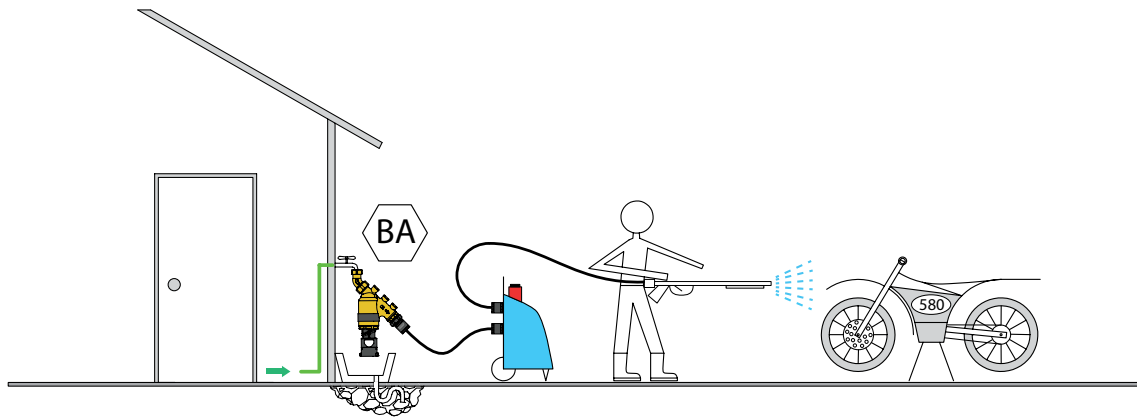

28. Dentist's chair (cat. 2 for model A, cat. 5 for model B)

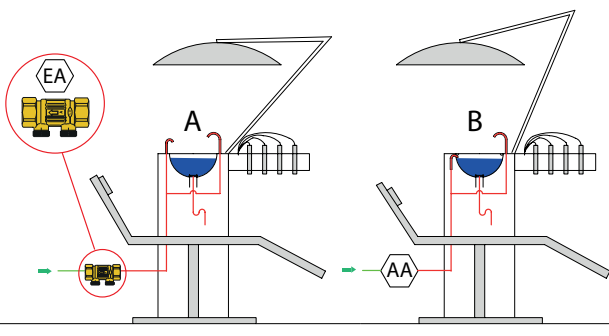

29. Drinking troughs for animals (cat. 5)

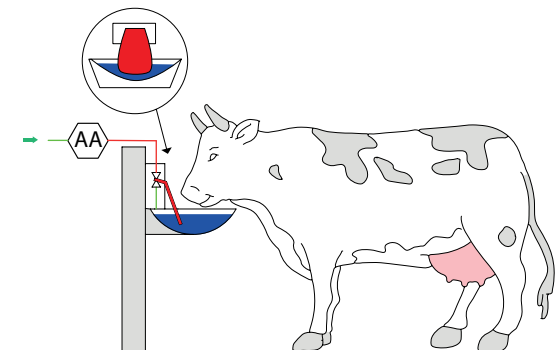

30. Filling or topping up of fountains or swimming pools (cat. 5)

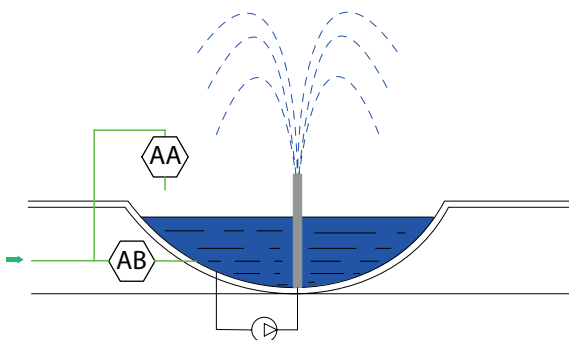

31. In-ground garden irrigation systems. Pop-up sprinklers (cat. 5)

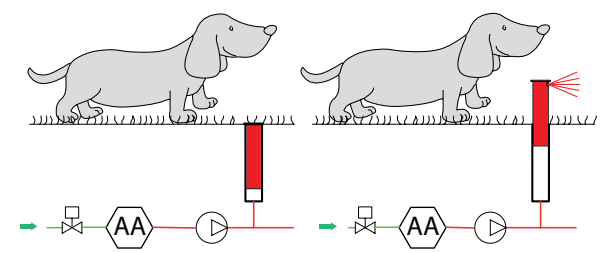

ANTI-POLLUTION CHECK VALVES



3045 tech. broch. 01005
Check valve.
EA type. Controllable. Brass body.
Medium: potable water.
Maximum working pressure: 10 bar.
Check valve minimum opening pressure (Δp): 0,5 kPa.
Maximum working temperature: 90 °C.
Certified to EN 13959.



Code	DN internal check valve	Connections
304540	15	1/2" F
304550	20	3/4" F
304560	25	1" F
304570	32	1 1/4" F
304580	40	1 1/2" F
304590	50	2" F



3046 tech. broch. 01005
Check valve.
EA type. Controllable.
Brass body.
Captive nut connections - male.
Maximum working pressure: 10 bar.
Maximum working temperature: 90°C.
Certified to EN 13959.



Code	DN internal check valve	Connections
304645	15	3/4" F x 3/4" M



3046 tech. broch. 01005
Compact check valve, EA type. **EA type.** Controllable. Brass body.
Captive nut connections - male.
Maximum working pressure: 10 bar.
Maximum working temperature: 90°C.
Certified to EN 13959.



Code	DN internal check valve	Connections
304601	15	3/4" F x 3/4" M



3047 tech. broch. 01005
Check valves. **EB type.**
Medium: potable water.
Maximum working pressure: 10 bar.
Check valve minimum opening pressure (Δp): 0,5 kPa.
Maximum working temperature: 90°C.



Code	DN internal check valve	Connections
304740	15	1/2" F
304750	20	3/4" F
304760	25	1" F



3046 tech. broch. 01005
Check valve. **EA type.** Controllable.
Brass body.
Captive nut connections - male.
Maximum working pressure: 10 bar.
Maximum working temperature: 90°C.
Certified to EN 13959.



Code	DN internal check valve	Connections
304640	15	3/4" F x 3/4" M
304650	20	1" F x 1" M
304660*	25	1 1/4" F x 1 1/4" M
304670*	32	1 1/2" F x 1 1/2" M
304680*	40	2" F x 2" M

* Not NF and SVGW certified



3048 tech. broch. 01005
Double check valve.
Controllable. Brass body.
Female - female connections.
Maximum working pressure: 10 bar.
Maximum working temperature: 90°C.



Code	DN internal check valve	Connections
304840	15	1/2" F
304850	20	3/4" F



3046 tech. broch. 01005
Check valve. **EA type.** Controllable.
Brass body.
Captive nut connections - male.
Maximum working pressure: 10 bar.
Maximum working temperature: 90°C.
Certified to EN 13959.



Code	DN internal check valve	Connections
304644	15	3/4" F nut x 3/4" M
304654	20	1" F nut x 1" M



3041 tech. broch. 01005
Ball valve with approved built-in check valve. Controllable.
Brass body.
Captive nut connections - male.
Maximum working pressure: 10 bar.
Maximum working temperature: 90°C.



Code	DN internal check valve	Connections
304140	15	3/4" F nut x 3/4" M

ANTI-POLLUTION CHECK VALVES

Operating principle

The anti-pollution check valve consists of a valve body (1), a check valve (2) and, if necessary, one or more pressure test ports (3) for operation checking and system testing. The check valve (2) delimits two distinct zones: one upstream or at the inlet (A), and one downstream or at the outlet (B).

Correct flow conditions

In correct flow conditions, the check valve (2) opens automatically when the pressure in the flow direction upstream (A) is greater than the downstream value (B).

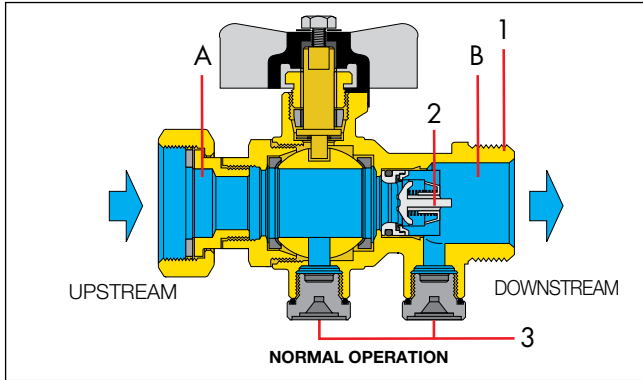

No flow conditions

The check valve (2) closes in advance under the action of the force exerted by the spring when the pressure downstream (B) begins to equal the value upstream (A), after the flow has stopped.

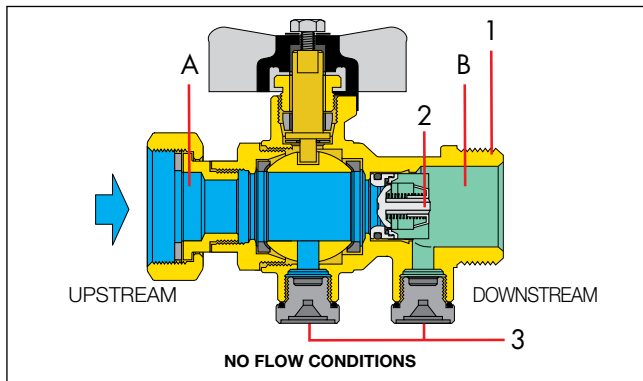

Upstream pressure loss

The check valve (2) remains closed, preventing water which has already been sent to the user from flowing back towards the public network.

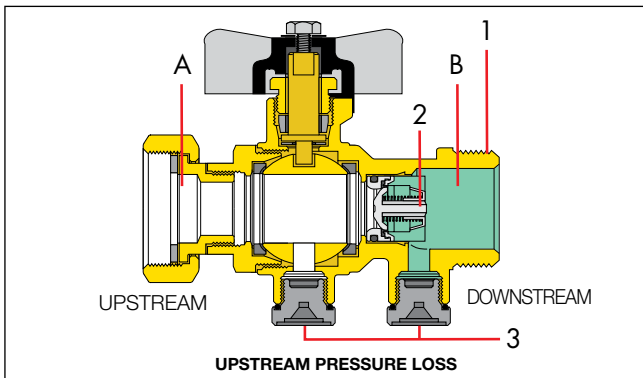

Downstream counter pressure

If the pressure in the downstream zone (B) increases until it exceeds the upstream pressure value (A), the check valve (2) remains closed, thus preventing water that has already been sent to the user from flowing back towards the mains water system.

Installation and maintenance procedures (operation check)

EA - EC TYPE

Installation

Before installation, make sure that the device is suitable for protecting the supply system, in relation to the type of medium used in the system. The controllable check valve should be installed in an accessible position upstream of a shut-off valve.

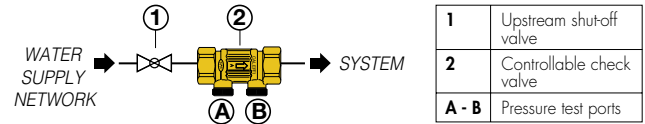

Before installing, flush the pipe with a high flow rate water jet: lack of cleaning can easily result in impaired operation of the product. Inspection and maintenance (operation check) procedures should be carried out at least once a year, in accordance with EN 806-5.

Inspection

Check whether the installation standards still require the application of the same device for the type of medium used in the system. Make sure that the hazard level of the medium in the system has not altered over time. Check that the surrounding environment is clean, the valve is accessible and that there are no leaks, corrosion or deterioration.

Maintenance (operation check)

To test the seal of the check valve, check that the valve closes each time the pressure in the upstream water supply drops, thus preventing water from the system flowing back into the water supply line:

- to maintain pressure in the installation in the absence of flow, close all shut-off valves or users downstream of the valve. Using the downstream test port (B), check that the pressure is greater than 0,5 bar.
- close the upstream shut-off valve (1) and open the test port (A) of the check valve. The flow should stop once the upstream section of pipe has emptied;
- if not, check the sealing-tightness of the upstream shut-off valve (1): if this valve is sealing correctly but the flow from the test port (A) continues, replace the check valve, as the flow can only be caused by imperfect sealing of the valve;
- test port (B) (if present) can be used with a pressure gauge to test system pressure downstream of the check valve.

EB TYPE

Installation

The EB check valve installation procedure is the same as that for the EA valve.

Inspection and maintenance (operation check)

Inspection and operation check procedures should be carried out at least once a year, in accordance with EN 806-5.

Inspection

The EB check valve inspection procedure is the same as that for the EA valve.

Maintenance (operation check)

Replace the valve every 10 years.

CHECK VALVES WITH SHUT-OFF



324 tech. broch. 01341

Anti-pollution check valve with built-in shut-off.

EA type.

Pressure test ports upstream and downstream.
Replaceable check valve cartridge.
"LOW LEAD" dezincification resistant alloy body **CR**.
Medium: potable water.
Maximum working pressure: 10 bar.
Check valve minimum opening pressure (Δp): 0,5 kPa.
Maximum working temperature: 65°C.
Certified to EN 13959 and EN 13828 standards.
PATENT PENDING.



Code	DN internal check valve	Connections
324140	20	1/2" M
324150	20	3/4" M

Operating principle

The anti-pollution check valve with built-in shut-off valve is comprised of a valve body (1), a check valve (2), two test ports (3) – one upstream for operation checks and one downstream for system pressure testing – a shut-off ball valve (4) with control lever (5).

The check valve (2) delimits two distinct zones: one upstream or at the inlet (A), and one downstream or at the outlet (B).

Operating conditions

Three possible operating conditions can be obtained according to the position of the control lever:

- 1) lever longitudinal to the valve: normal operating conditions
- 2) lever perpendicular to the valve, rotated clockwise through 90° relative to the longitudinal position: EA check valve operation check
- 3) lever perpendicular to the valve, rotated anti-clockwise through 90° relative to the longitudinal position: operation access to EA check valve for maintenance or replacement.

Correct flow conditions

In correct flow conditions, the check valve (2) opens automatically when the pressure in the flow direction upstream (A) is greater than the downstream value (B).

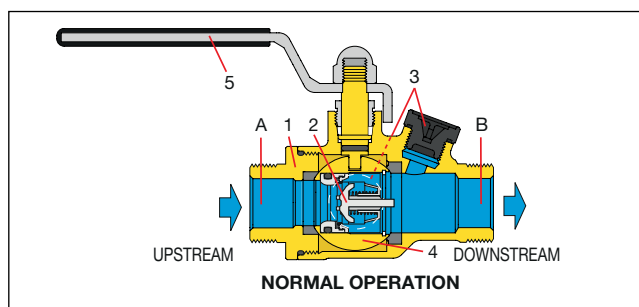

No flow conditions

The check valve (2) closes in advance under the action of the force exerted by the spring when the pressure downstream (B) begins to equal the value upstream (A), after the flow has stopped.

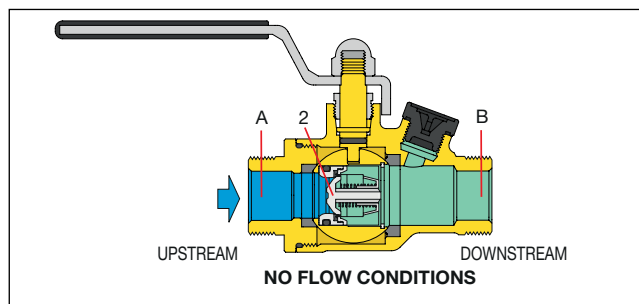

Upstream pressure loss

The check valve (2) remains closed, preventing water which has already been sent to the user from flowing back towards the public network.

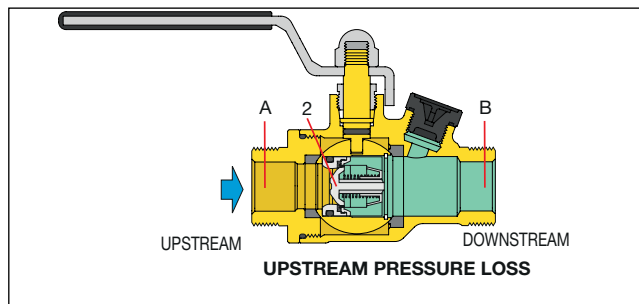

Downstream counter pressure

If the pressure in the downstream zone (B) increases until it exceeds the upstream pressure value (A), the check valve (2) remains closed, thus preventing water that has already been sent to the user from flowing back towards the mains water system.



324 tech. broch. 01341

Anti-pollution check valve with built-in shut-off.

EA type.

Pressure test ports upstream and downstream.
Replaceable check valve cartridge.
"LOW LEAD" dezincification resistant alloy body **CR**.
Medium: potable water. Maximum working pressure: 10 bar.
Check valve minimum opening pressure (Δp): 0,5 kPa.
Maximum working temperature: 65°C.
Certified to EN 13959 and EN 13828 standards.
PATENT PENDING.



Code	DN internal check valve	Connections
324250	20	3/4" F nut x 3/4" M



324 tech. broch. 01341

Anti-pollution check valve with built-in shut-off.

EA type.

Pressure test ports upstream and downstream.
Replaceable check valve cartridge.
"LOW LEAD" dezincification resistant alloy body **CR**.
Medium: potable water.
Maximum working pressure: 10 bar.
Check valve minimum opening pressure (Δp): 0,5 kPa.
Maximum working temperature: 65°C.
Certified to EN 13959 and EN 13828 standards.
PATENT PENDING.



Code	DN internal check valve	Connections
324110	20	Ø 15
324120	20	Ø 22

CHECK VALVES WITH SHUT-OFF

Installation and maintenance procedures (operation check)

For installation and inspection, refer to the indications in the previous pages for EA and EC type devices.

Maintenance (operation check)

To test the seal of the check valve, check that the valve closes each time the pressure in the upstream water supply drops, thus preventing water from the system flowing back into the water supply line:

a. to maintain pressure in the installation in the absence of flow, close all shut-off valves and users downstream of the valve. Using the downstream test port, check that the pressure is greater than 0,5 bar.

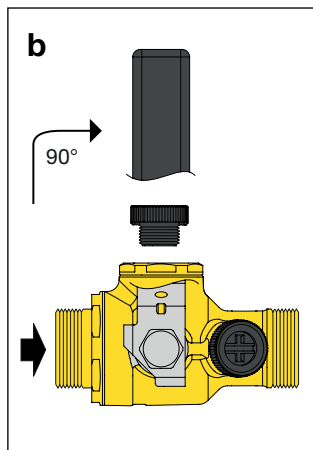

b. close the built-in shut-off valve, rotating it clockwise through 90° relative to the longitudinal position, and open the check valve test port. The flow should stop after the small amount of medium contained in the valve body between the shut-off and pressure test port has drained off;

c. if not, check the seal of the built-in shut-off valve: if this valve is sealing correctly but the flow from the test port continues,

replace the check valve, as the flow can only be caused by imperfect sealing of the valve;

d. the pressure gauge, supplied as an optional item, can be used to test system pressure downstream of the check valve.

Replacement of the check valve

Thanks to the special patented design, all operation check or replacement operations can be carried out using just one shut-off valve:

- position the lever perpendicular to the valve body by raising it slightly and rotating it anti-clockwise through 90° relative to the longitudinal position;
- open the side cap;
- remove the snap ring;
- use pliers to remove the check valve, taking care not to damage it. Carry out the maintenance operations, position the original or replacement check valve in its seat and refit by reversing the removal procedure.

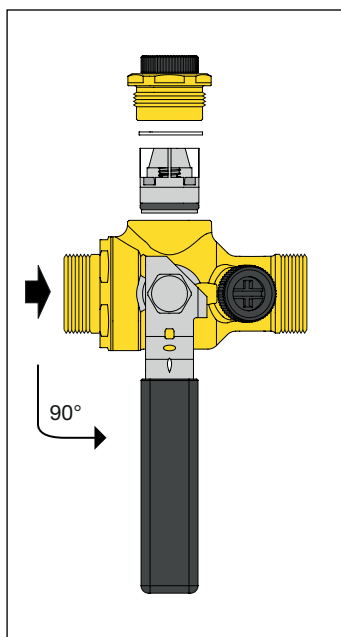

BALLSTOP

3230/33.  tech. broch. 01021

Ball valve with built-in check valve.
Brass body.
Medium: water.
Maximum working pressure: 16 bar.
Check valve minimum opening pressure (Δp): 0.02 bar.
Working temperature range: 5–90 °C.



Code	Connections
323040	1/2" F butterfly handle
323050	3/4" F butterfly handle
323062	1" F butterfly handle
323060	1" F lever handle
323070	1 1/4" F lever handle
323080	1 1/2" F lever handle
323090	2" F lever handle
332400	1/2" M x 1/2" F butterfly handle
333400	1/2" F x captive nut 3/4" F butterfly handle
333500	3/4" F x captive nut 3/4" F butterfly handle
334400	1/2" M x captive nut 3/4" F butterfly handle
334500	3/4" M x captive nut 3/4" F butterfly handle

Operating principle

The valve consists of a ball (1) containing a suitably hydraulically-shaped check valve obturator (2). During normal circulation of the medium within the system, the obturator is pushed against the counter-spring (3) inside it, so as to open the channel to allow the medium to flow through. When the pressure downstream of the valve exceeds the upstream value, the obturator is pushed in the opposite direction, against the seal seat on the ball (4), in order to prevent medium back flow. Plus, when there is no flow, the valve closes thanks to the action of the counter-spring. The obturator, thanks to the thrust produced by the counter-spring (3) and the downstream pressure, completely shuts off the flow of medium through the specially shaped seal (5) (positioned on the ball seal seat or on the obturator, depending on the version). The ball, equipped with a butterfly handle (6) or lever depending on the size of the valve, acts as a normal shut-off device.

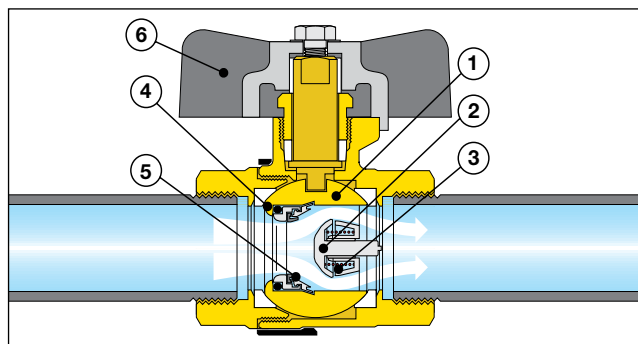

Installation

The Caleffi 3230, 332, 333 and 334 series BALLSTOP ball valves with built-in check valve are designed for use in domestic water systems which require an interceptable check valve.

The ball shut-off valve with built-in check valve should be installed in the system in accordance with the flow direction indicated on the plastic band applied to the valve body. The valve can be fitted in any position, horizontal, vertical, or upside down.

The inspection and maintenance (operation check) of BALLSTOP valves series 3230-332-333-334 should be carried out with the same frequency and using the same procedures as indicated for EB type check valves.

CA TYPE BACKFLOW PREVENTERS



572

Non-controllable backflow preventer with different pressure zones, for domestic gas boilers.

CAb type. Brass body. PN 10.

Fittings for Ø 6 copper pipe.

Maximum working temperature: 40 °C.

Certified to EN standard 14367.



Code

572106



573

tech. broch. 01328

Non-controllable backflow preventer with different pressure zones. **CAa type.**

Brass body. PN 10.

Female connections with union.

Maximum working temperature: 65 °C.

Certified to EN standard 14367.



Code

Connections

573415 1/2"

573515 3/4"

Normative references

According to product standard EN 14367, CA type backflow preventers are further subdivided into classes "a" and "b" according to the following technical requirements:

- backflow preventers in Family C, Type A, class "a", for general use, shall be capable of working at any pressure up to 1 MPa (10 bar), with any pressure variation up to 1 MPa (10 bar), at a supply temperature limit of 65 °C and 90 °C for one hour;
- backflow preventers in Family C, Type A, class "b", for specific use, shall be capable of working at any downstream pressure up to 0,3 MPa (3 bar) and with any downstream pressure variation up to 0,3 MPa (3 bar). CAb type backflow preventers, with specific hydraulic characteristics but no acoustic requirements, are intended for use as charging units in boilers for heating or heating/domestic hot water production. Such boilers can have a maximum power output of 70 kW and maximum working temperature of 110 °C.

Operating principle

The CA type non-controllable backflow preventer with different pressure zones includes: an upstream check valve (1), a downstream check valve (2), a discharge device (3).

The two check valves mark off three different zones, each of which at a different pressure: an upstream or inlet zone (A); an intermediate zone, also known as the reduced pressure zone (B); a downstream or outlet zone (C).

The discharge device (3) is located in the intermediate zone. The discharge device (3) is connected directly to the diaphragm (4). This mobile assembly is opened and closed by the difference in pressure between upstream and downstream of the check valve and by the counter spring (5).

Correct flow conditions

Under correct conditions of flow, both check valves (1 and 2) are open, while the pressure in the intermediate chamber (B) is always lower than the pressure upstream (A) due to a pre-calculated head loss at the first check valve (1). As a result, this pressure difference acts on the internal diaphragm (4) and generates a force that keeps the drain valve closed (3), communicating with the atmosphere, pressing on the counter-spring (5).

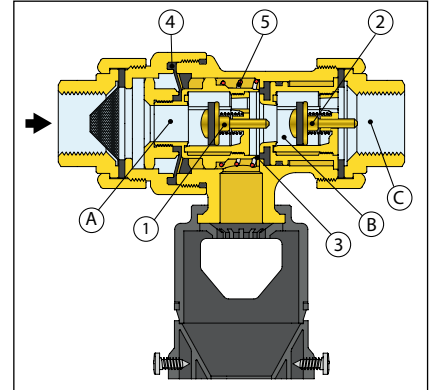

No flow conditions

The check valves (1 and 2) are now closed. Due to the difference in pressure that still exists between the upstream zone (A) and the intermediate zone (B), the drain valve (3) remains closed.

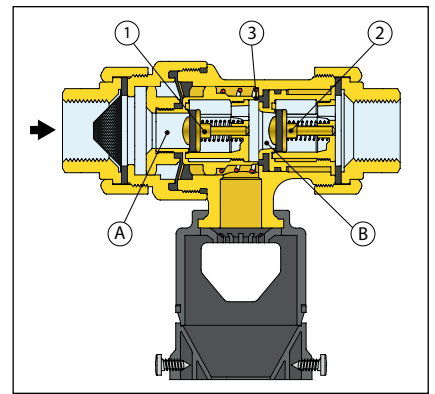

Upstream pressure loss

Both check valves (1 and 2) close as the pressure upstream drops. The drain valve (3) opens at the moment in which the difference in pressure Δp , existing between the upstream (A) and intermediate (B) zones reaches a value just below the one pre-calculated for the counter spring (5). Drainage continues until the intermediate chamber of the backflow preventer is empty.

This creates a (safety) air zone and prevents the contaminated water in the circuit, originating from zone (C), from returning into the water distribution mains, also in case of check valve (2) failure.

When the situation returns to normal (pressure upstream greater than pressure downstream), the drain valve closes and the backflow preventer is again ready to operate.

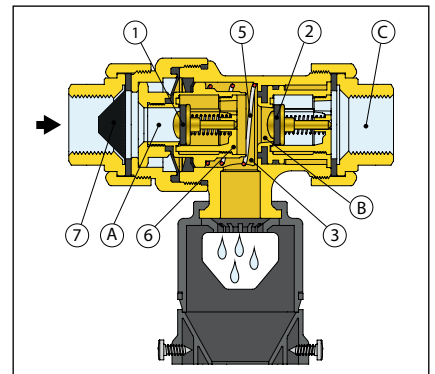

Downstream counter pressure

If the pressure in the downstream zone (C) increases until it exceeds the upstream pressure value (A), the check valve (2) closes, thus preventing the water that has already been sent to the user from flowing back towards the water main.

Should check valve (2) have a slight sealing problem, or in general should any other malfunction occur in the backflow preventer, the latter will always shut off (disconnect) the connection between the user and the water main.

In fact the backflow preventer was designed with all the construction solutions required for a positive action device; the best possible safety conditions are therefore ensured under all conditions.

CA TYPE BACKFLOW PREVENTERS

Construction details

Corrosion-proof materials

The materials used to manufacture the backflow preventers must be immune from corrosion caused by contact with potable water, and these characteristics must be maintained over time. For this reason, they have been made using dezincification resistant alloy for the central obturator seat (6) and the check valves (1-2), and stainless steel for the springs and strainer (7).

Elastomers complying with food regulations

The elastomers used for the hydraulic seals have been approved by the Certifying Bodies in accordance with the most recent provisions regarding compatibility for use with potable water.

Stainless steel strainer

The backflow preventer is fitted with a stainless steel strainer (7) upstream, to prevent impurities or dirt from causing damage to the check valve seals (1-2) or the central obturator internal mechanism (6) over time.

Installation and maintenance procedures (operation check)

Installation

The backflow preventer must be installed horizontally with a shut-off valve and an inspectable strainer upstream and another shut-off valve downstream.

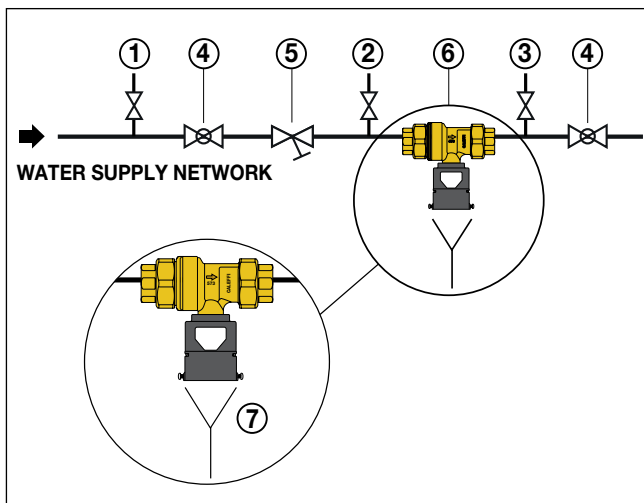

- 1 Water mains control cock
- 2 Upstream control cock
- 3 Downstream control cock
- 4 Upstream/downstream shut-off valve
- 5 Y-strainer
- 6 Backflow preventer, 573 series with inspectable strainer at the inlet
- 7 Drain to sewerage

The unit must be installed in an accessible area that is large enough to prevent it getting submerged by any accidental flooding. The drain valve must be appropriately connected to a drain.

Before installing, flush the pipe with a high flow rate water jet: lack of cleaning can easily result in impaired operation of the product.

According to standard EN 806-5, inspection procedures must be carried out once every six months. The maintenance (operation check) procedures should be carried out at least once a year.

Inspection

Check for possible changes in the use of the water downstream from the device and the suitability of the unit to protect the water mains.

Make sure there is accessibility to the protection unit and ventilation of the place of installation; that the installation position is not subject to immersion in the case of flooding, and that there is protection against frost and excessively high temperature conditions.

Check functionality of the components of the protection unit (valves, strainer, pressure test ports), vertical positioning of the drain, the distance of the device from the drainage conveyance system, and the surface conditions (corrosion or deterioration).

Any potential backflow can be no greater than the device's discharge capacity: also check the ability of the drainage circuit to receive the discharged water and the presence of water in the syphon, if fitted.

Maintenance (operation check)

1. Discharge checking operation (disconnection).

A pressure drop in the water mains upstream of the valve must cause the drain valve to open, with consequent emptying of the water contained in the valve body:

- Close the shut-off valves upstream and downstream (4) of the backflow preventer.
- Open control cock (2) to lower the upstream pressure. The device should intervene by opening the drain to empty the water inside the valve body.

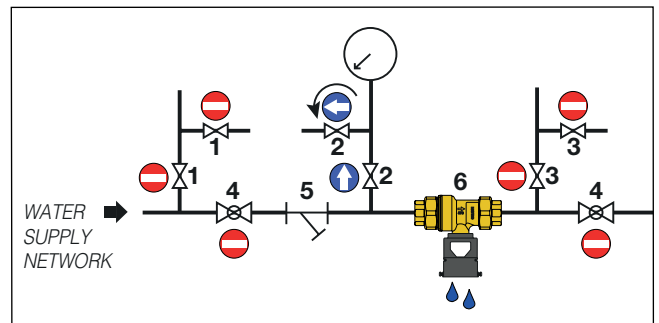

2. Check the tightness of the second check valve.

In case of downstream counter pressure of the backflow preventer, the second check valve must close to prevent reverse flow of the water:

- Close the shut-off valves upstream and downstream (4) of the backflow preventer.
- Open control cock (2) to lower the upstream pressure.
- Install a by-pass hose to connect control cock (1) to control cock (3) downstream: open both cocks to carry the mains pressure downstream of the second check valve. If there is no more water discharged from the drain valve, this means that the second check valve is working correctly.

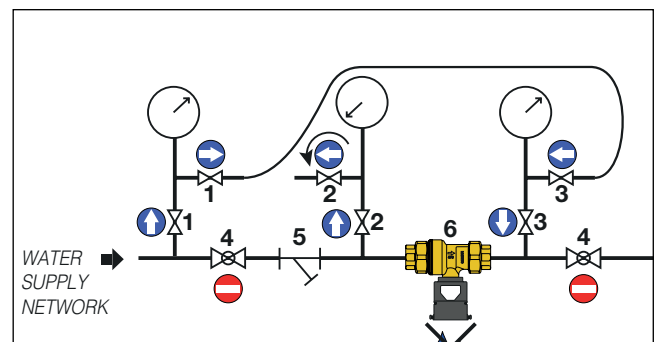

If symptoms of incorrect operation persist after having performed the checking procedure described above, the entire backflow preventer must be replaced with a new device, since it is not possible to access the internal components to replace individual parts.

BA TYPE BACKFLOW PREVENTERS



580  **tech. broch. 01322**
 BA Type **backflow preventer** with multi-function geometry.
 Dezincification resistant alloy body **CR**.
 PN 10. Max. working temperature 65 °C.
 Maximum differential operating pressure 14 kPa.
Certified to EN standard 12729.



Code	DN	Connections
580004	15	1/2" M with union
580040	15 (DN 20 cartridge)	1/2" M with union
580050	20	3/4" M with union
580060	25	1" M with union
580070	32	1 1/4" M with union



580  **tech. broch. 01322**
 BA type **backflow preventer** with multi-function geometry for special applications.
 Dezincification resistant alloy body **CR**.
 PN 10.
 Max. working temperature 65 °C.
 Maximum differential operating pressure 14 kPa.
Certified to EN standard 12729.



Code	DN	Connections
580104	15	3/4" nut x 3/4" M
580150	20	3/4" nut x 3/4" M
580240	15 (DN 20 cartridge)	1/2" M x 3/4" M
580250	20	3/4" M x 3/4" M

Operating principle

The controllable reduced pressure zone backflow preventer is composed of: a body (1); a self-contained cartridge (2) equipped with an upstream check valve (3); a downstream check valve (4); a discharge device integrated with the cartridge (5). The two check valves mark off three different zones, each of which at a different pressure: an upstream or inlet zone (A); an intermediate zone, also known as the reduced pressure zone (B); a downstream or outlet zone (C). Each of these is equipped with a test port connection for pressure measurement. A discharge device (5) is located in the lower part of the intermediate zone. The obturator of the discharge device is connected to the diaphragm (6). This mobile unit is pushed upwards by the spring (7). The diaphragm (6) separates the upstream zone from the intermediate zone.

Correct flow conditions

Under normal flow conditions, both check valves (3 and 4) are open, while the pressure in the intermediate chamber (B) is always lower than the inlet pressure (upstream A) by at least 14 kPa due to the pressure drop caused by the check valve (3). In this situation, the mobile unit consisting of the diaphragm (6) and the valve obturator (5) is pushed down by the thrust created by the difference in pressure acting on the diaphragm, which is greater than that of the spring (7) acting in the opposite direction. The drain valve (5) is therefore held in the closed position.

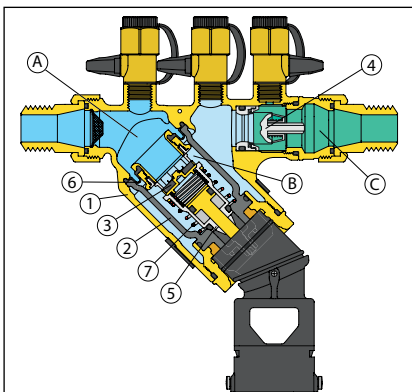

No flow conditions

The check valves (3) and (4) are now closed. Since the pressure in the upstream zone (A) is still at least 14 kPa higher than the pressure in the intermediate chamber (B), the drain valve (5) remains closed.

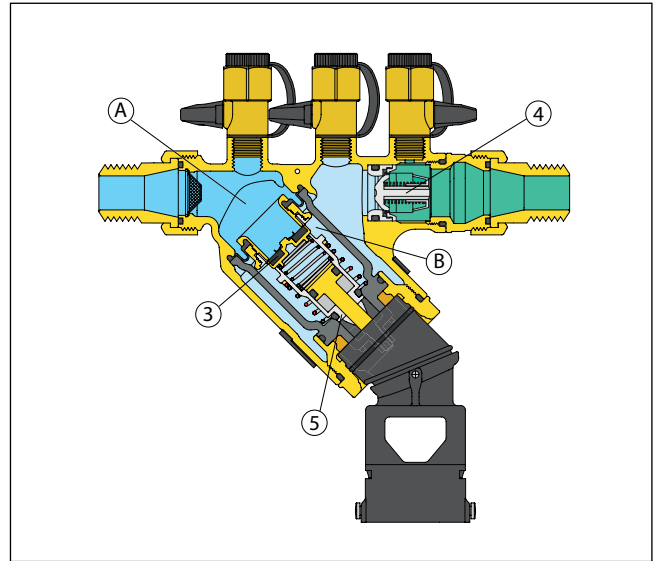

Upstream pressure loss

The check valves (3 and 4) close as the pressure upstream (A) drops. The drain valve (5) opens when the difference in pressure Δp between the upstream (A) and intermediate (B) zones falls, reaching a value a little bit higher than 14 kPa. Under these conditions the action exerted by the pressure difference Δp on the diaphragm (6) becomes weaker than that exerted by the spring (7) and the drain valve (5) opens as a result. Discharge then occurs until the body of the backflow preventer is empty. When the situation returns to normal (upstream pressure (A) greater than downstream pressure (C)), the drain valve (5) closes and the backflow preventer is again ready to operate.

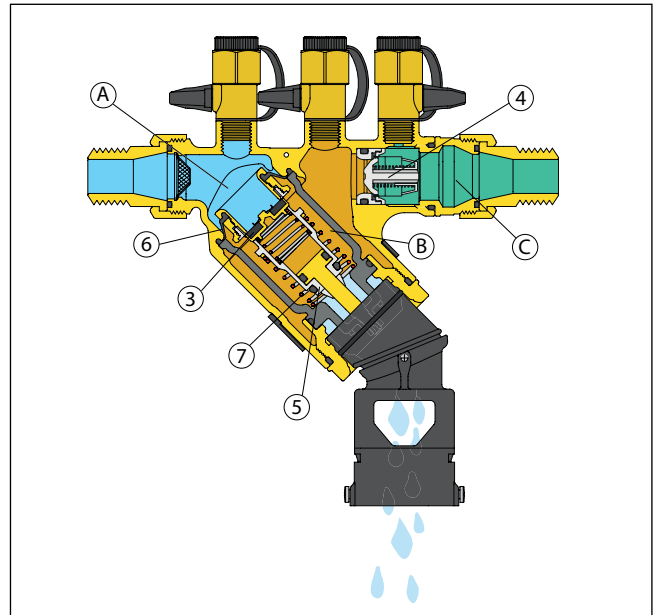

Downstream counter pressure

If the pressure in the downstream zone (C) increases until it exceeds the upstream pressure value (A), the check valve (4) closes, thus preventing the water that has already been sent to the user from flowing back towards the water main. If the seal of the check valve (4) is slightly defective or in general terms there is any other type of fault in the backflow preventer, the device always interrupts (disconnects) the connection between the mains system and the user system. The backflow preventer has been designed with all construction details required for a properly functioning positive action device; the best possible safety conditions are therefore ensured under all conditions.

BA TYPE BACKFLOW PREVENTERS

Construction details

Self-contained cartridge and diaphragm

The self-contained cartridge comprises, all in one piece, the diaphragm, the upstream check valve, the drain valve and the whole activation system. In case of maintenance, it can be easily extracted from the body without the aid of further seal elements.

The diaphragm, integrated with the cartridge, separates the upstream zone from the intermediate zone. It also acts as a hydraulic seal between the two zones. For this reason, there are no O-rings between the two zones.

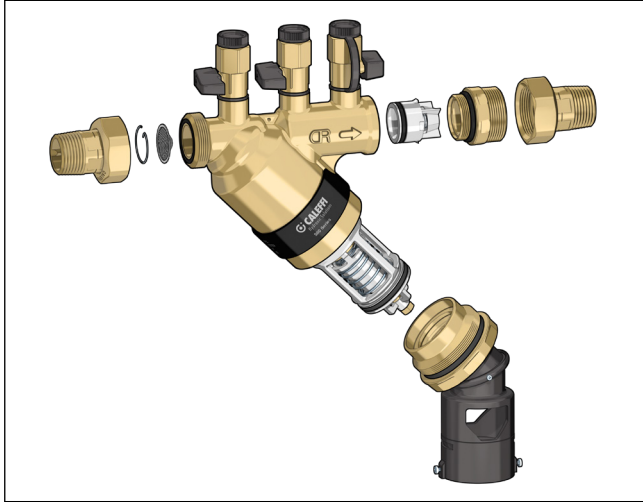

Discharge tundish

In compliance with standard EN 1717, backflow from the connected pipe must be prevented during water discharge from the backflow preventer, and discharge must occur without any water sprinkling to the outside. Consequently the tundish connected to the discharge pipe must be of an appropriate size with special openings to create the necessary air gap and it must be equipped with a suitable flow conveyor. Thanks also to the possibility of orienting the tundish, the same body can be used in three different configurations: installation on horizontal or vertical pipes or for special applications.



Built-in upstream strainer

The upstream strainer, required by the protection unit according to standard EN 1717, is located in the upstream connection of the valve body and is easily accessible for maintenance.

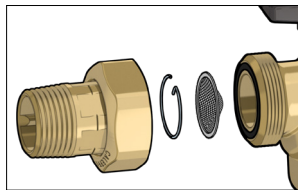
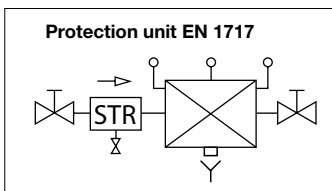

Downstream check valve

The downstream check valve is positioned before the outlet connection and is held in place by a special locking nut. For maintenance, just remove the downstream union and the locking nut.

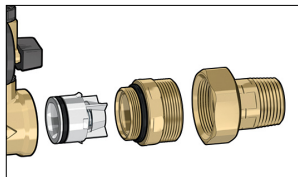

Hose connection

The version for special applications is provided as standard with a 3/4" hose connection x 1/2" pipe on the outlet connection.

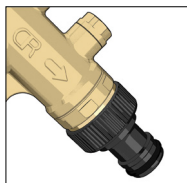

Versatility

The version for in-line installation (on a horizontal or vertical pipe) can be easily converted into a version for special applications, and vice versa, thanks to the interchangeability of the upstream union with the elbow union and the shut-off valve upstream.

Thanks to the compactness and versatility of the body, the 580 series backflow preventer is suitable for protecting systems with mediums of even lower than category 4, so that only one device need be kept in stock.

Corrosion-proof materials

The materials used to manufacture the backflow preventers must be insensitive to corrosion caused by contact with potable water. They are therefore constructed using a dezincification resistant alloy, plastic materials and stainless steel to ensure high performance over time.

Installation and maintenance procedures (operation check)

The backflow preventer must be installed in an accessible zone, where there is no risk of accidental flooding or frost. If there is a risk of frost, especially for the backflow preventer version for special applications, it is recommended to remove the device during the coldest hours. The discharge tundish must be turned downwards and connected to the pipe leading to the sewer.

For the protection of the public mains the backflow preventer must be installed after the water meter, whereas in order to protect the tap water outlets of the domestic internal network it should be installed at the limit of the areas where there may be contamination due to backflow.

The in-line backflow preventer, codes 580040/050, must be installed with one shut-off valve upstream and one downstream (not supplied in the package). According to the indications of regulation EN 1717, the backflow preventer is equipped with an inspectable strainer, located in the upstream connection of the body and easily accessible for maintenance, and an adjustable discharge tundish. The appliance should be installed horizontally, in accordance with the flow direction indicated by the arrow on the valve body. Installation on a vertical pipe with downward flow (from top to bottom) is also allowed, respecting the direction of flow indicated by the arrow on the valve body. In the case of particularly dirty mediums, consider installing an additional inspectable strainer upstream.

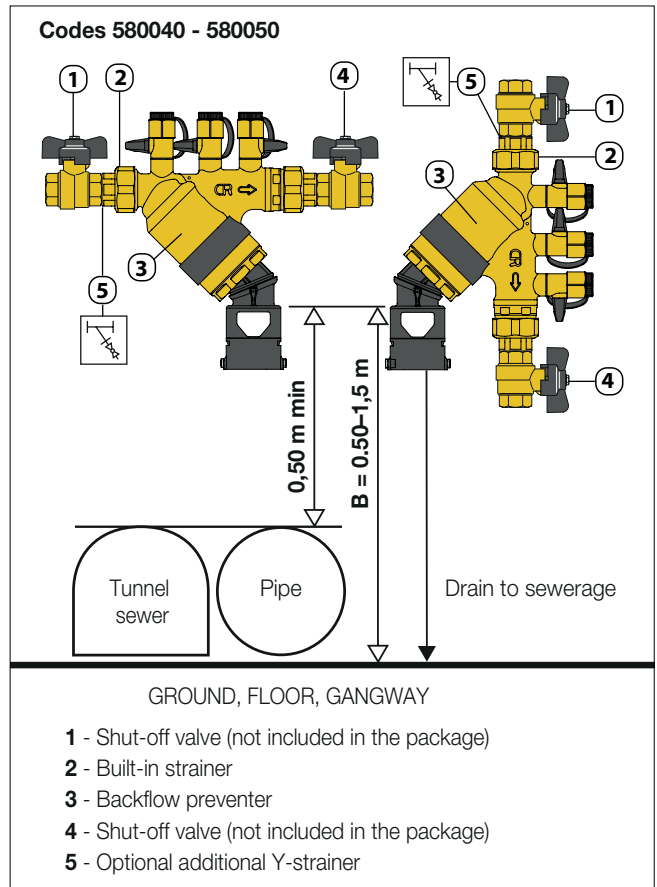

BA TYPE BACKFLOW PREVENTERS

The backflow preventer for special applications code 580150, equipped with a captive nut, must be fitted to the cock which thus performs the function of an upstream shut-off valve. The backflow preventer for special applications 580240/250 must be fitted directly to the pipe, as it is already equipped with an upstream shut-off valve. The connection between valve, fitting and backflow preventer can be blocked with the seal supplied in the package. According to the indications of regulation EN 1717, the backflow preventer is equipped with an inspectable strainer, located in the upstream connection of the body and easily accessible for maintenance, and an adjustable discharge tundish. The appliance must be installed with a downward flow (from top to bottom), respecting the direction of flow indicated by the arrow on the valve body. In the case of particularly dirty mediums, consider installing an additional inspectable strainer upstream.

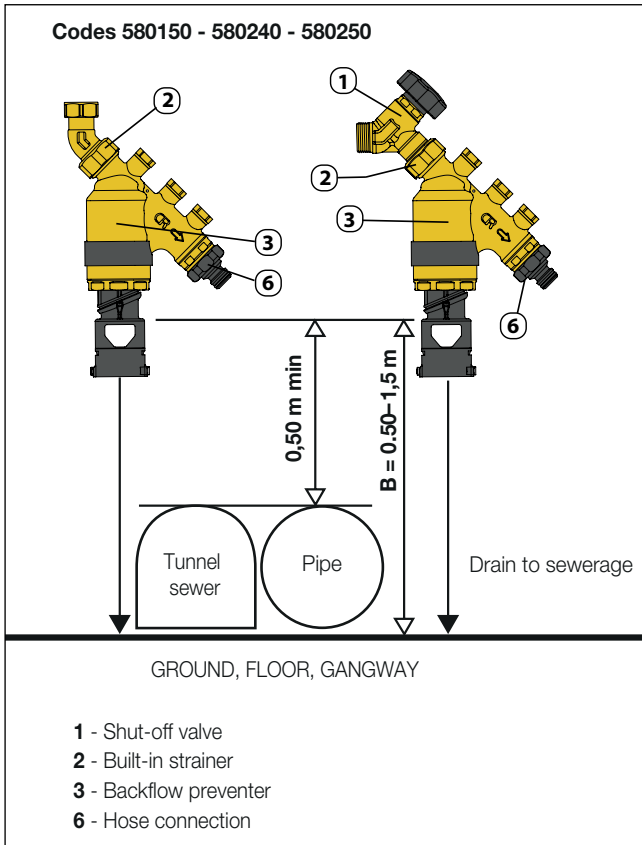

Inspection and maintenance (operation check)

For BA type backflow preventers, inspection procedures must be carried out every six months. While maintenance procedures (operation check) must be carried out at least once a year, in accordance with EN 806-5.

Inspection

Check for possible changes in the use of the water downstream from the device and the suitability of the unit to protect the water mains. Check accessibility to the protection unit, ventilation of the place of installation, that the installation position is not subject to immersion in the case of flooding, protection against frost and excessively high temperature conditions. Check functionality of the components of the protection unit (valves, strainer, pressure test ports), vertical positioning of the drain, the distance of the device from the drainage conveyance system, and the surface conditions (corrosion or deterioration). Any potential backflow can be no greater than the device's discharge capacity: also check the ability of the drainage circuit to receive the discharged water and the presence of water in the syphon, if fitted.

Maintenance (operation check)

The procedure involves: removal and cleaning of the upstream strainer; seal test for valves and gaskets; operation check of the backflow preventer (check valves seal and disconnection in accordance with manufacturer's instructions); cleaning of the discharge tundish; pressure testing using suitable instruments (static, dynamic, differential); logging of results of operations performed.

Functional testing of the backflow preventer can be carried out by means of a differential pressure gauge, with two Tee fittings each of which with a pressure release cock.

1. Checking the upstream check valve

Code 580040/050, series 574-575-570: check for the presence of the shut-off valves upstream and downstream of the backflow preventer. Close the upstream and downstream shut-off valves.

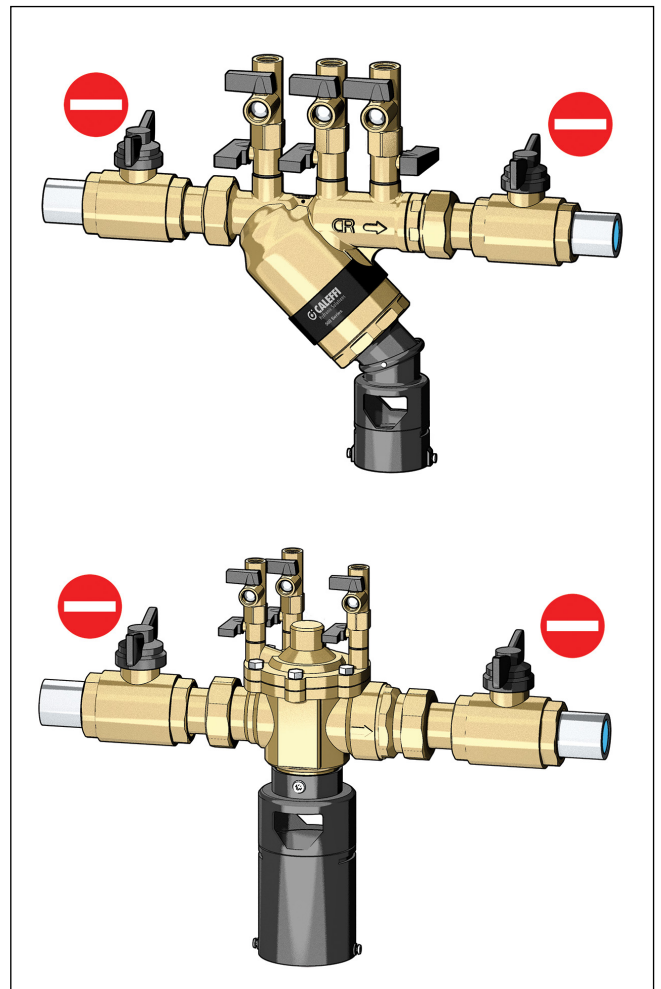

BA TYPE BACKFLOW PREVENTERS

Code 580150/240/250: close the upstream shut-off valve; fit a shut-off valve in place of the hose connector outlet on the backflow preventer and close the valve; apply the upstream, intermediate and downstream pressure test ports by removing the threaded caps.

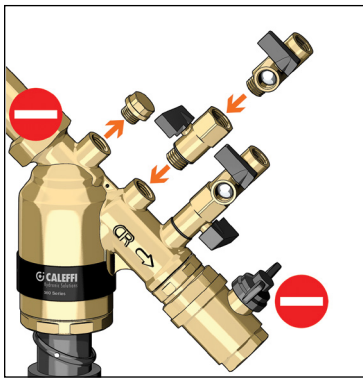
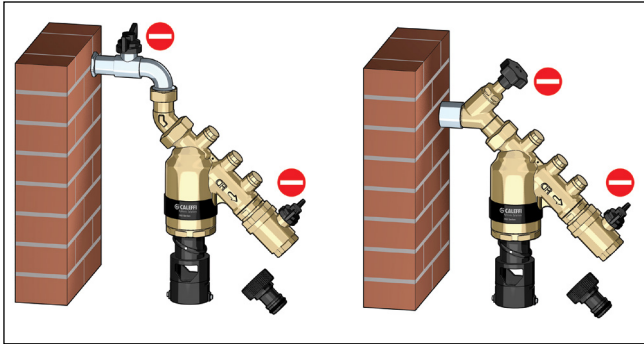

For all codes: connect the differential pressure gauge to the upstream and intermediate pressure test ports. Open the two pressure test ports connected to the differential pressure gauge while keeping the downstream pressure test port closed. Open the upstream and downstream shut-off valves. Open a downstream tap to cause a high flow rate to pass through the valve. Close the upstream and

downstream shut-off valves to achieve static conditions. If the Δp value decreases, this means the check valve is not water-tight and it must be checked by removing it from the valve body. The Δp value may fall to a safety value (above 14 kPa) at which disconnection occurs. If the pressure differential value Δp remains constant and above 14 kPa, the check valve is functioning correctly and you may continue with next stage.

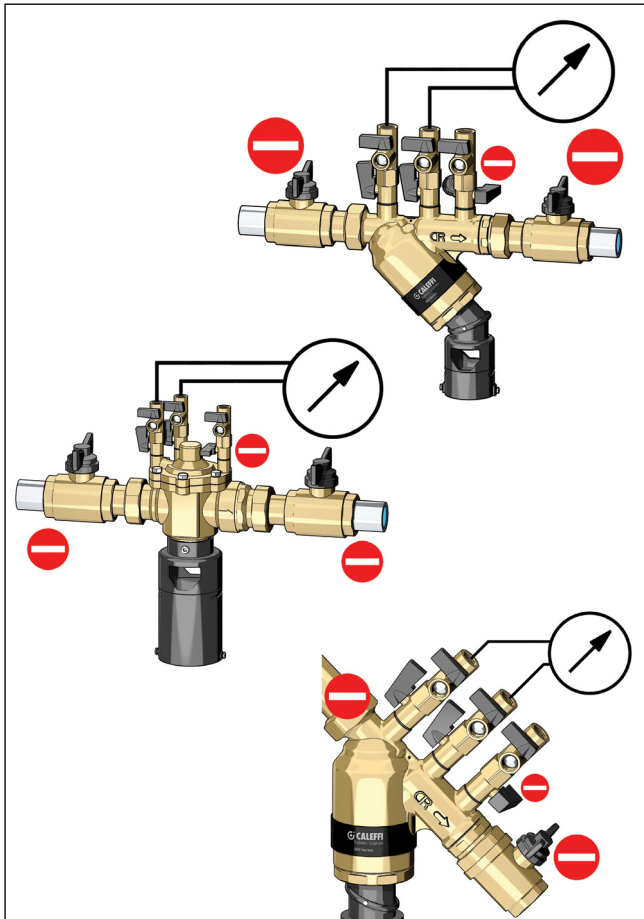

2. Disconnection test

Keep the differential pressure gauge connected to the upstream and intermediate pressure test ports. Open the two test ports connected to the differential pressure gauge while keeping the downstream pressure test port closed. Open the upstream pressure release cock to reduce the upstream pressure. Disconnection must occur at Δp value greater than 14 kPa. Log the Δp value at which the device disconnects in the commissioning report.

3. Checking the downstream check valve

Close the upstream and downstream shut-off valves. Close the pressure test ports. Connect the differential pressure gauge to the intermediate and downstream pressure test ports while keeping the upstream pressure test port closed. Open the upstream and downstream shut-off valves. Once again, subject the valve to a high flow rate and then close the upstream and downstream shut-off valves. Check that the Δp value between the intermediate chamber and the downstream chamber, as shown on the pressure gauge, is above 0,5 kPa and that this value remains constant when the downstream pressure is gradually reduced by opening the pressure release cock on the downstream pressure test port. If the Δp value does not remain constant, this means the check valve is not water-tight and it must be checked by removing it from the valve body.

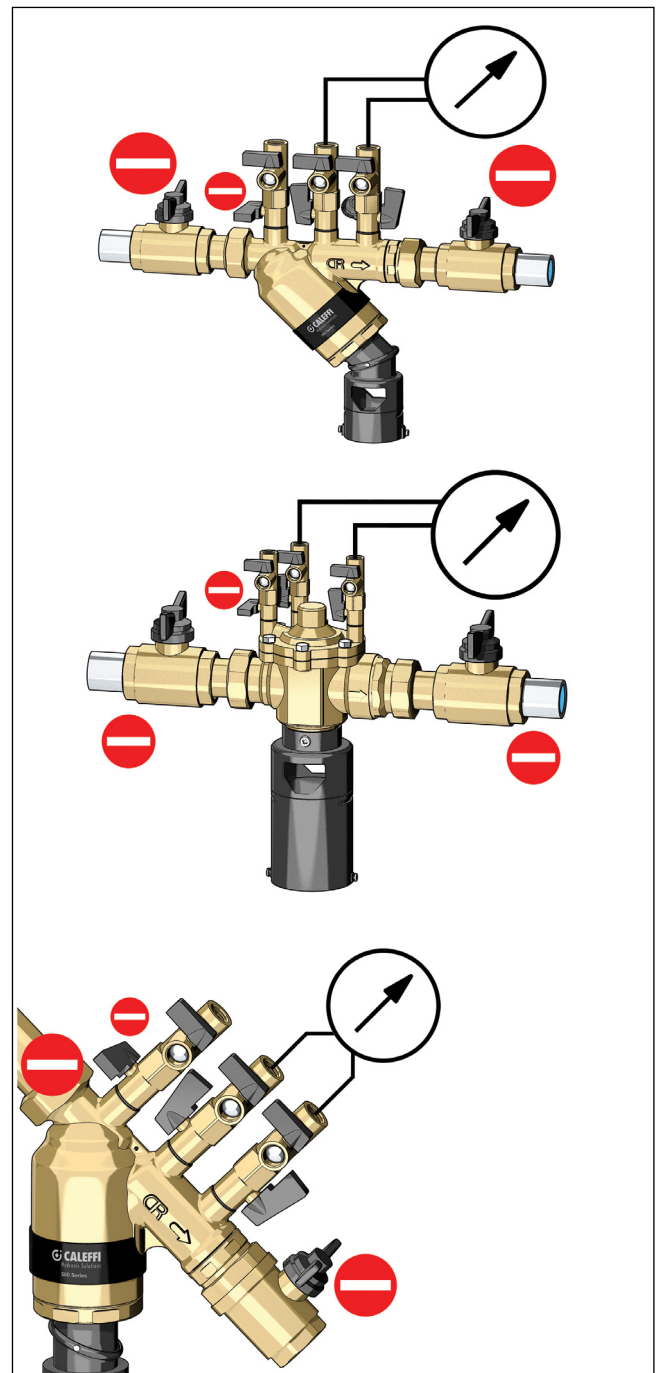

BA TYPE BACKFLOW PREVENTERS



574

tech. broch. 01022

Controllable reduced pressure zone backflow preventer. **BA Type.**
"LOW LEAD" dezincification resistant alloy body **CR.**
 PN 10. Male pipe union connections.
 Maximum working temperature: 65 °C.
 Operating pressure differential: 14 kPa.
Certified to EN standard 12729.
 It is essential to install the 577 series strainer upstream.



Code	Connections
574004	1/2"



574

tech. broch. 01022

Controllable reduced pressure zone backflow preventer. **BA Type.**
"LOW LEAD" dezincification resistant alloy body **CR.**
 PN 10. Male pipe union connections.
 Maximum working temperature: 65 °C.
 Operating pressure differential: 14 kPa.
Certified to EN standard 12729.
 It is essential to install the 577 series strainer upstream.



Code	Connections
574040	1/2"
574050	3/4"
574006	1"
574600	1"
574700	1 1/4"
574008	1 1/2"



574/575

tech. broch. 01022

Controllable reduced pressure zone backflow preventer. **BA Type.**
 Bronze body. PN 10.
 Male pipe union connections and flanged PN 16 connections.
 Coupling with counterflange EN 1092-1.
 Maximum working temperature: 65 °C.
 Differential operating pressure 14 kPa.
Certified to EN standard 12729.
 It is essential to install the 577 (574) or 579 (575) series strainer upstream.



Code	Connections
574800	1 1/2" with union
574900	2" with union
575005	DN 50 flanged PN 16
575006	DN 65 flanged PN 16
575008	DN 80 flanged PN 16
575010	DN 100 flanged PN 16



575

tech. broch. 01245

Controllable reduced pressure zone backflow preventer. **BA Type.**
 Epoxy resin coated cast iron body.
 PN 10.
 Flanged PN 16 connections.
 Coupling with counterflange EN 1092-1.
 Maximum working temperature: 60°C.
 Operating pressure differential: 14 kPa.
Certified to EN standard 12729.
 It is essential to install the 579 series strainer upstream.



Code	Connections
575150	DN 150
575200	DN 200
575250	DN 250



570

tech. broch. 01022

Assembly consisting of:
 574 series backflow preventer;
 577 series Y-strainer;
 manual shut-off valves.
 PN 10.
 Female-female connections.
 Maximum working temperature: 65 °C.

Code	Connections
570004	1/2"
570005	3/4"
570006	1"
570007	1 1/4"
570008	1 1/2"
570009	2"

570

Assembly consisting of:
 575 series backflow preventer;
 579 series Y-strainer;
 manual shut-off valves. PN 10.
 Flanged PN 16 connections.
 Coupling with counterflange EN 1092-1.
 Maximum working temperature: 65°C (DN 50–DN 100).
 Maximum working temperature: 60°C (DN 150–DN 250).



Code	Connections	Description
570050	DN 50	Backflow preventer body in bronze
570060	DN 65	Backflow preventer body in bronze
570080	DN 80	Backflow preventer body in bronze
570100	DN 100	Backflow preventer body in bronze
570150	DN 150	Backflow preventer body in cast iron
570200	DN 200	Backflow preventer body in cast iron
570250	DN 250	Backflow preventer body in cast iron

BA TYPE BACKFLOW PREVENTERS

Operating principle

The controllable reduced pressure zone backflow preventer is composed of: a body with an inspection cover, an upstream check valve (1), a downstream check valve (2), a discharge device (3). The two check valves mark off three different zones, each of which at a different pressure: an upstream or inlet zone (A); an intermediate zone, also known as the reduced pressure zone (B); a downstream or outlet zone (C). Each of these is equipped with a test port connection for pressure measurement. A discharge device (3) is located in the lower part of the intermediate zone. The obturator of the discharge device is connected via the valve stem (4) to the diaphragm (5). This mobile unit is pushed upwards by the counter-spring (6). The diaphragm (5) marks the limit of the operation chamber (D), which is connected to the upstream zone by the channel (7).

Correct flow conditions

Under normal flow conditions, both check valves are open, while the pressure in the intermediate chamber (B) is always lower than the inlet pressure by at least 14 kPa to the pressure drop caused by the check valve (1). In the operation chamber (D), however, the pressure is the same as in the inlet zone. In this situation, the mobile unit consisting of the diaphragm (5), the valve stem (4) and the valve obturator (3) is pushed down by the thrust created by the difference in pressure acting on the diaphragm which is greater than that of the spring (6) acting in the opposite direction. The drain valve is therefore held in the closed position.

Under these conditions the action exerted by the pressure difference Δp on the diaphragm (5) becomes weaker than that exerted by the counter-spring (6) and the drain valve (3) opens as a result. Discharge then occurs until the body of the backflow preventer is empty. When the situation returns to normal (pressure upstream greater than pressure downstream), the drain valve closes and the backflow preventer is again ready to operate.

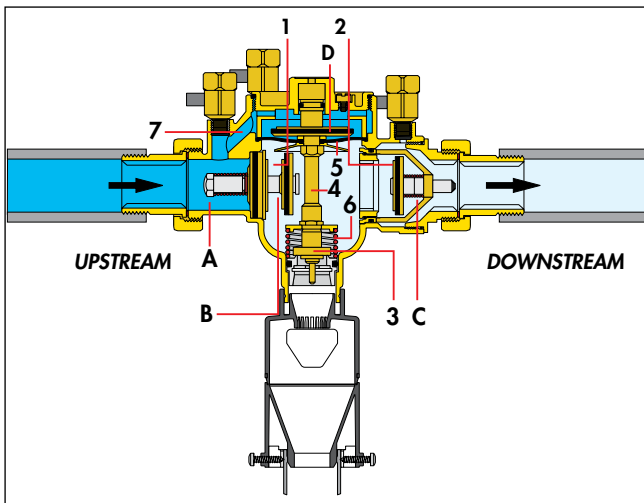
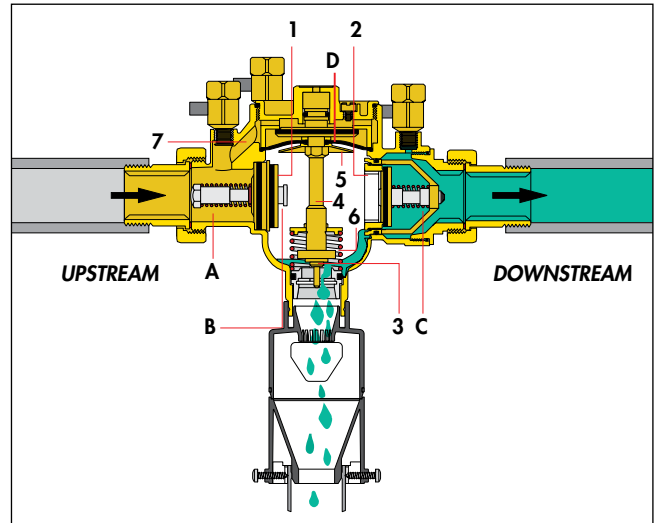

Downstream counter pressure

If the pressure in the downstream zone increases until it is greater than the upstream pressure, the check valve (2) closes and therefore prevents water already delivered to the user from returning back into the mains system. If the seal of the check valve (2) is slightly defective or in general terms there is any other type of fault in the backflow preventer, the device always interrupts (disconnects) the connection between the mains system and the user system. The backflow preventer has been designed with all construction details required for a properly functioning positive action device; the best possible safety conditions are therefore ensured under all conditions.

Installation and maintenance procedures (operation check)

Installation

The backflow preventer must be installed on a horizontal pipe with a shut-off valve and an inspectable strainer upstream and a further shut-off valve downstream. The backflow preventer must be installed in an accessible zone, where there is no risk of accidental flooding or frost. The discharge tundish must be oriented downwards and connected to the sewer.

Before installing the backflow preventer and strainer, flush the pipe with a high flow rate.

Inspection and maintenance (operation check)

For BA type backflow preventers, inspection procedures must be carried out every six months. While maintenance procedures (operation check) must be carried out at least once a year, in accordance with EN 806-5. For a description of the procedures, see page 22.

No flow conditions

The check valves (1) and (2) are now closed. Since the pressure in the upstream zone, and therefore also in the operation chamber (D), is still at least 14 kPa higher than the pressure in the intermediate chamber (B), the drain valve remains closed.

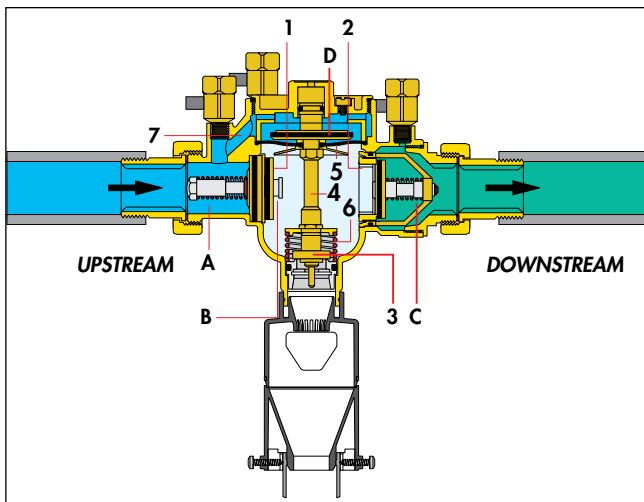

Upstream pressure loss

Both check valves close as the pressure upstream drops. The drain valve (3) opens at the moment in which the difference in pressure Δp , existing between the upstream and intermediate zones, decreases to reach a value just over 14 kPa.

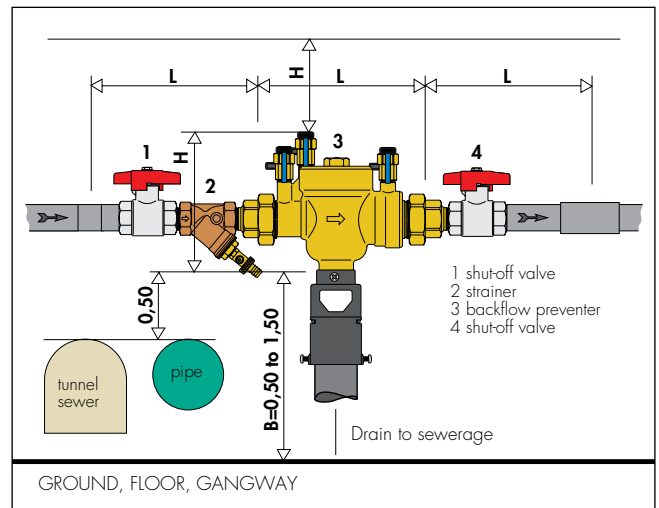

CHARGING UNITS

58001.

 tech. broch. 01333

Automatic compact filling unit to EN 1717 with **BA type** backflow preventer, shut-off valves, strainer, pressure test ports for checking the backflow preventer, pressure reducing valve.

Dezincification resistant alloy body **CR** (code 580010).

Chrome plated brass body (code 580011).

With insulation.

Adjustment range of the filling unit: 0,8–4 bar.

Maximum working pressure: 10 bar.

Maximum working temperature: 65°C.

Backflow preventer conforming to EN 12729.

Pressure reducer to EN 1567.

PATENT PENDING.



Code 580010



Code 580011

Code	Connections	Charging flow rate @ $\Delta p = 1,5$ bar (m ³ /h)
580010	1/2"	1.5
580011	1/2"	1.1

Function

The compact automatic charging unit is composed of a shut-off valve with an inspectable strainer, a BA type controllable reduced pressure zone backflow preventer and an automatic filling unit. It is installed on the water inlet piping in closed circuit heating systems. It maintains the pressure of the system stable at a set value, automatically topping up with water as required. The backflow preventer prevents the contaminated water of the closed heating circuit from flowing back into the domestic water supply network, in compliance with the provisions of EN 1717.

Characteristic components

1. Compact, self-contained body
2. Two shut-off valves
3. Three pressure test ports
4. BA type backflow preventer cartridge (EN 12729)
5. Charging unit cartridge (pressure reducer) (EN 1567 - W570-3)
6. Inspectable/removable upstream strainer
7. Inspectable/removable downstream check valve (EN 13959)
8. Discharge tundish (EN 1717)
9. Insulation
10. Pressure gauge connection on two sides

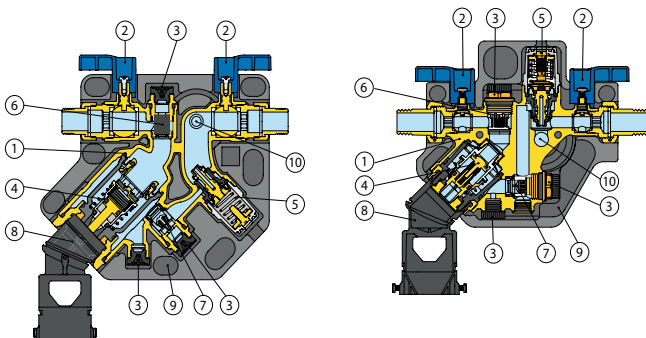

Protection unit

The compact filling unit comprises all the devices required by EN 1717 to form the protection unit for the BA backflow preventer (shut-off valves, inspectable strainer), in addition to the pressure reducing valve (charging unit).

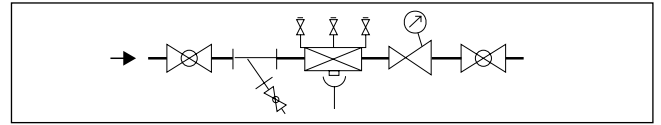

Construction details

Self-contained cartridge and diaphragm of the backflow preventer

The self-contained cartridge comprises, all in one piece, the diaphragm, the upstream check valve, the drain valve and the whole activation system. In case of maintenance, it can be easily extracted from the body without the aid of further seal elements. The diaphragm, integrated with the cartridge, separates the upstream zone from the intermediate zone. It also acts as a hydraulic seal between the two zones, there are no O-rings between the two zones.

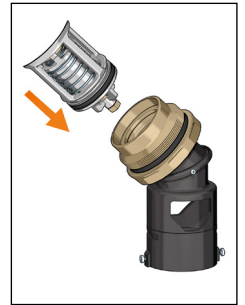

Automatic filling unit

The system filling pressure may be set by turning the regulating screw during the system filling phase. The effective pressure is read on the pressure gauge.

The cartridge containing the diaphragm, strainer, seat, obturator and compensation piston is a pre-assembled self-contained unit with a cover and can be removed to facilitate inspection and maintenance procedures.

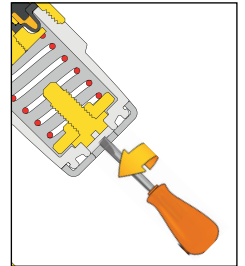

Shut-off valves, pressure test ports and upstream inspectable strainer

The shut-off valves and the three pressure test ports (to EN 12729) allow periodic operation checks of the backflow preventer and the pressure reducing valve in accordance with EN 806-5.

The upstream inspectable strainer, in accordance with EN 1717, protects the backflow preventer from any impurities in the mains water supply that could impair its operation.

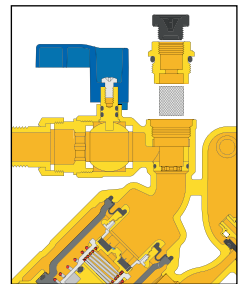

Downstream check valve

The downstream check valve is positioned before the filling unit and is held in place by a locking nut. For maintenance, simply remove the cap and the locking nut.

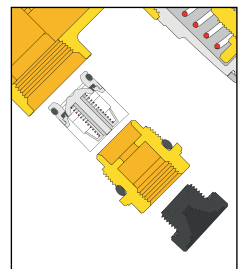

Compact design and versatility

The adjustable discharge tundish means that the charging unit can be installed on horizontal and vertical pipes, with upward flow.

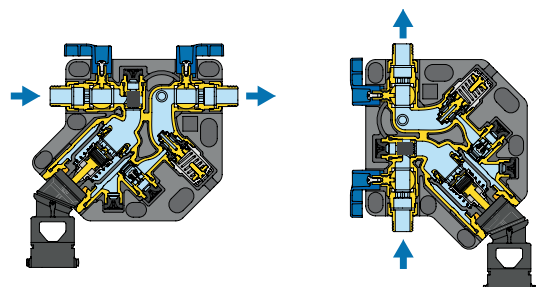

CHARGING UNITS

Operating principle

The filling unit assembly is comprised of a shut-off valve, an inspectable strainer, a backflow preventer and a filling unit. It is installed on the water inlet pipe in closed circuit heating systems, and its main function is to keep the system pressure stable at a set value by automatically topping up with water as required. The purpose of the backflow preventer is to prevent the contaminated water of the closed heating circuit from flowing back into the domestic water supply network, in compliance with provisions of EN 1717.

573001

 **tech. broch. 01061**

Automatic charging unit with **CAa type** backflow preventer and shut-off valves.

Adjustment range of the filling unit: 0,2–4 bar.

Maximum working pressure: 10 bar.

Maximum working temperature: 65 °C.

Backflow preventer certified to EN standard 14367.



Code	Connections
------	-------------

573001	1/2"
--------	------

574000

 **tech. broch. 01061**

Automatic charging unit with **BA type** backflow preventer, Y-strainer and shut-off valve.

Adjustment range of the filling unit: 0,2–4 bar.

Maximum working pressure: 10 bar.

Maximum working temperature: 65 °C.

Backflow preventer certified to EN 12729.



Code	Connections
------	-------------

574000	1/2"
--------	------

574001

 **tech. broch. 01125**

Charging unit with **BA type** backflow preventer, Y-strainer and shut-off valve.

Reducer adjustment range: 1–6 bar.

Maximum working pressure: 10 bar.

Maximum working temperature: 60 °C.

Backflow preventer certified to EN 12729.



Code	Connections
------	-------------

574001	3/4"
--------	------



*We reserve the right to make changes and improvements to our products and the related technical data in this publication, at any time and without prior notice.
The website www.caleffi.com always has the most up-to-date version of the document, which should be used for technical verifications.*



CALEFFI S.p.A. · S.R.229, N.25 · 28010 Fontaneto d'Agogna (NO) · Italy
Tel. +39 0322 8491 · info@caleffi.com www.caleffi.com

© 2022 Copyright Caleffi

