

# 502 Minical

automatic air vent

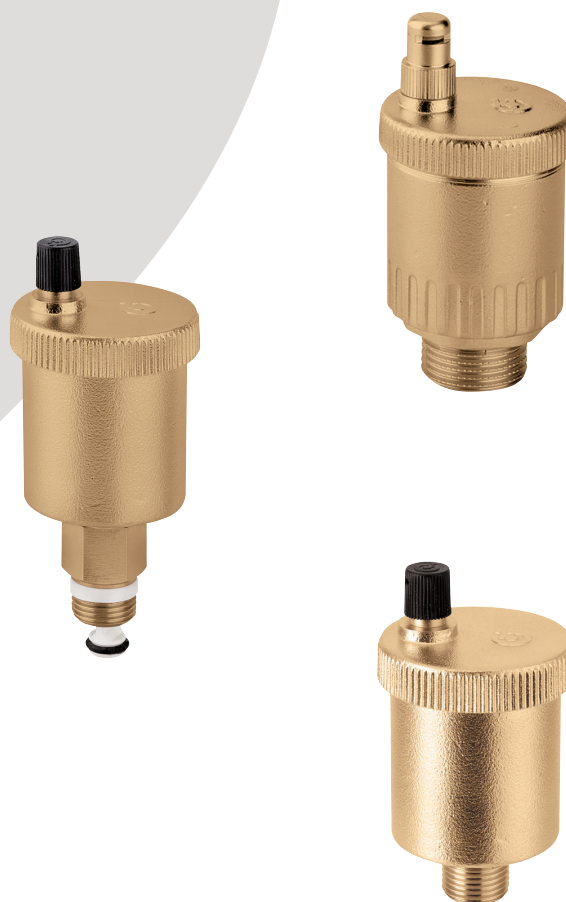

**altecnic**  
CALEFFI group

# 502 Minical automatic air vent



502030/40



502130/40



502050/60

## Application

The Altecnic series 502 automatic air vents are used in heating and air conditioning systems to continually remove air from the system without the need for manual adjustment.

Excessive air within a system can cause excessive noise, reduce the accuracy of control valves and the performance of heating and cooling equipment.

One of the most important functions of the Altecnic automatic air vents is to release air as the system is being filled with water and then automatically isolating, preventing water loss and wastage from the system.

## Materials

Components	Material	Specification
Body	Brass	BS EN 12165 CW617N
Cover	Brass	BS EN 12165 CW617N
Float	Polymer	Polypropylene
Spring	Stainless steel	
'O' rings	Elastomer	EPDM
Check valve seals	PTFE	

## Technical Data

Medium:	water, glycol solution
Max. percentage of glycol:	30%
Temperature range:	0 to 120°C
Max. working pressure:	10 bar

## WRAS approved products

Product Ref	Size	Connection	Max Venting Pressure	Type - with
502030	3/8"	male screwed	2.5 bar	
502130	3/8"	male screwed	2.5 bar	check valve
502040	1/2"	male screwed	2.5 bar	
502140	1/2"	male screwed	2.5 bar	check valve
502050	3/4"	male screwed	2.5 bar	hydroscopic cap
502060	1"	male screwed	2.5 bar	hydroscopic cap

## Hydroscopic Cap

All Minical automatic air vents can be supplied with a hydroscopic safety cap.

Its function is based on the properties of the cellulose fibre disc who's volume increases by 50% as soon as it becomes wet, causing the valve to close avoiding possible leakage.

© Patents & Design Altecnic 2024

Altecnic Ltd retains all rights (including patents, designs and copyrights, trademarks and any other intellectual property rights) in relation to all information provided on or via the website, brochures or any other documents, including all texts, graphics and logos, contained on the website, in brochures or in any other documents published in the name of or on behalf of Altecnic Ltd in any form, without prior written consent of Altecnic Ltd.

Altecnic Ltd Mustang Drive, Stafford, Staffordshire ST16 1GW

T: +44 (0)1785 218200 E: sales@altecnic.co.uk

Registered in England No: 02095101

altecnic.co.uk

AL 005 27-09-24

E & O.E

© Altecnic Limited. 2024

ALTECNIC™

## Dimensions

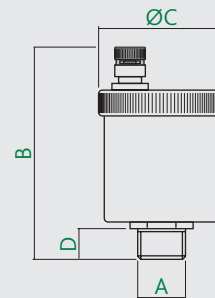

Prod Ref	A	B	C	D	kg
502030	G3/8B	79	48	11	0.18
502040	G1/2B	79	48	11	0.18

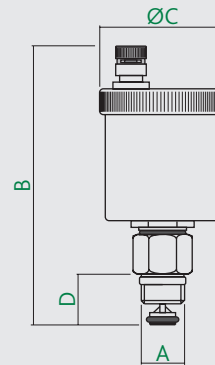

Prod Ref	A	B	C	D	kg
502130	G3/8B	96	48	19	0.21
502140	G1/2B	96	48	19	0.23

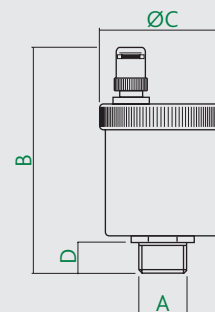

Prod Ref	A	B	C	D	kg
502050	G3/4B	86	48	19	0.18
502060	G1B	86	48	19	0.18

**altecnic**  
CALEFFI group