

518

differential bypass valve



**altecnic**  
CALEFFI group

# 518 differential bypass valve



## Introduction

The 518 bypass valve is installed in the bypass between the flow and return pipes and opens on rising differential pressure to allow flow through the bypass.

This maintains the differential pressure between the flow and return pipes at the predetermined set value and limits the maximum differential pressure generated by the pump.

Differential bypass valves are used in systems with variable flowrates. Radiator circuits utilising thermostatic radiator valves or heating systems incorporating 2-port control valves are typical applications. Differential bypass valves can be used in both constant and variable volume systems to prevent the differential pressure from rising, which can seriously affect the performance of the 2-port control valves.

## Design

The 518 differential bypass valves use a stainless steel compression spring to exert a pre-determined force onto the disc.

The force is adjustable by turning the control knob to set the required differential pressure between 1 to 6 m head which corresponds to 10 to 60 kPa.

The 519800 valve has a threaded female inlet and a threaded male union outlet.

The 518002 valve for use with copper tube has compression ends complying with BS EN 1252-2 for use with R250 (half hard) copper tube.

## Product Range

Ref No	Description
518500	¾" differential bypass valve
518002	22mm differential bypass valve

## Construction Details

Component	Material	Grade
Body:	Brass	BS EN 12165 CW617N
Obturator:	Polymer	PA6G300
Obturator seals:	Elastomer	EPDM
'O' rings	Elastomer	EPDM
Seals - union:	asbestos free	NBR
Control knob:	Polymer	ABS
Spring:	Stainless steel	

## Technical Specification

Medium:	water/glycol solution
Max. percentage of glycol:	30%
Max. working pressure:	10 bar
Working temperature range:	0 to 100°C
Setting range:	1 to 6 mwg 10 to 60 kPa

## Dimensions

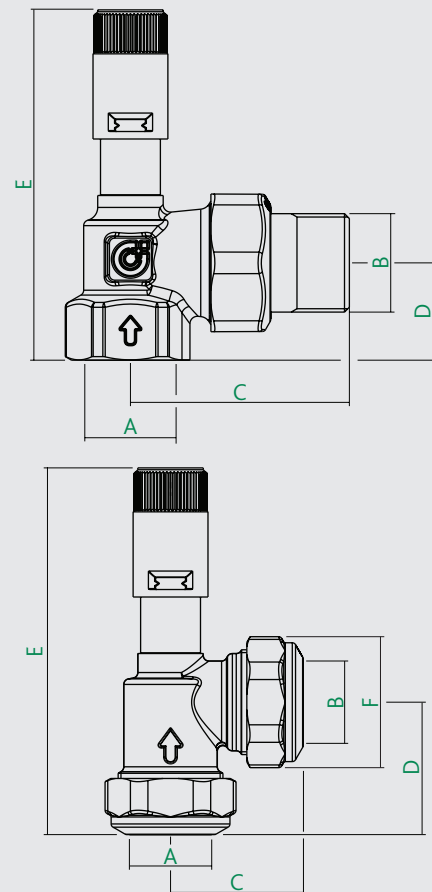

Ref No	A	B	C	D	E Max	F	kg
518500	G¾	G¾	58.5	26	93.6	-	-
518002	Ø22	Ø22	35.4	35.4	98	Ø35	-

## Installation

The differential by-pass valve can be fitted in any position, respecting the flow direction indicated by the arrow on the valve body.

In systems with a traditional boiler it is normally fitted between the system flow and return ends, which allows the pressure and passage of a minimum flow through the heat generator to be controlled.

In the event of high by-pass flow rate levels, it is recommended to fit the valve between the flow and return ends of each column, rather than fitting a number of valves in parallel at the central heating system.

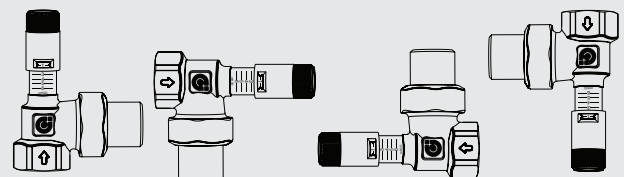

# 518 differential bypass valve

## Setting

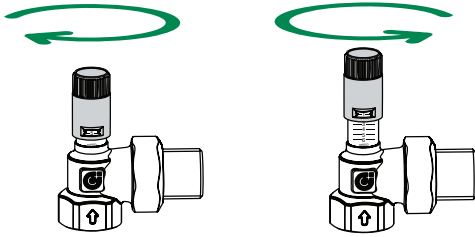

To regulate the valve, turn the knob to the value required on the graduated scale the values correspond to the differential pressure at which the by-pass is opened.

To carry out rapid by-pass valve adjustment it is possible to use the following practical method, which can be applied, for example, to the system in an apartment fitted with thermostatic valves: the system must be operating, the regulating valves must be fully open and the by-pass valve must be set to its maximum value position 6.

Close approximately 30% of the thermostatic valves.

Gradually open the valve using the control knob. Use a temperature gauge, or simply your hand, to check that the hot water is flowing into the by-pass circuit. As soon as a temperature rise is detected, open the thermostatic valves again and check that the hot water stops flowing into the by-pass.

## Hydraulic Characteristics

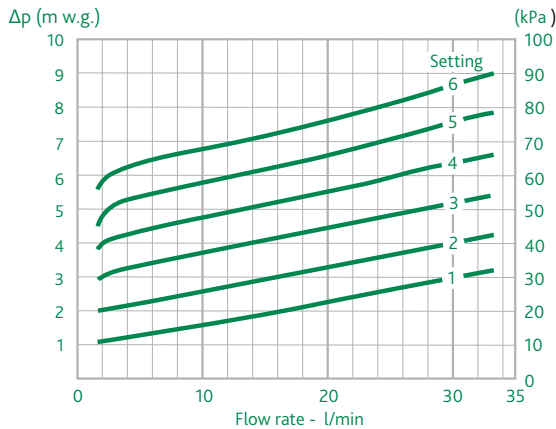

## System operation

The purpose of the by-pass valve is to maintain the pump operating point as close as possible to its nominal value (point A on the graph shown below).

If a by-pass valve is not used, when the flow rate in the circuit decreases due to partial closure of the two-way valves, the headloss in the circuit increases, point B.

The by-pass valve when set to the nominal head value of the pump limits the pressure increase, by-passing the flow rate  $\Delta G$ .

Once the position of the valve control knob has been established, the set pressure value is more or less constant as the discharge flow rate varies (see hydraulic characteristic diagrams).

Correct valve sizing guarantees a sufficient flow rate to by-pass to keep the pump at its nominal operating point in all system operating conditions, for example when the first thermostatic valves are closed.

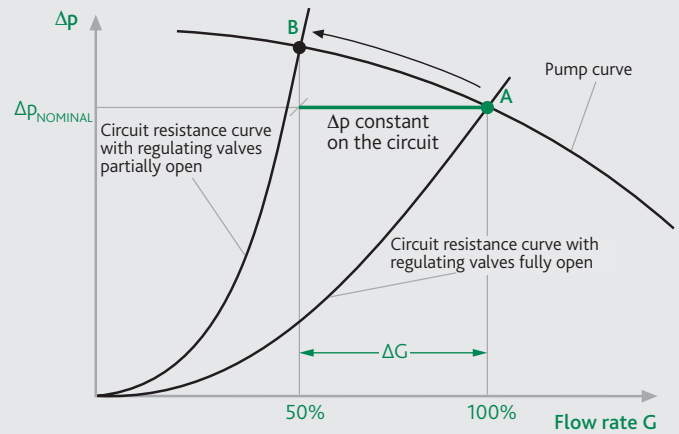

© Patents & Design Altecnic 2023

Altecnic Ltd retains all rights (including patents, designs and copyrights, trademarks and any other intellectual property rights) in relation to all information provided on or via the website, brochures or any other documents, including all texts, graphics and logos, contained on the website, in brochures or in any other documents published in the name of or on behalf of Altecnic Ltd in any form, without prior written consent of Altecnic Ltd.

Altecnic Ltd Mustang Drive, Stafford, Staffordshire ST16 1GW

T: +44 (0)1785 218200 E: sales@altecnic.co.uk

Registered in England No: 02095101

altecnic.co.uk

AL 499 29-11-23

E & O.E

© Altecnic Limited. 2023

ALTECNIC™

**altecnic**  
CALEFFI group