

5461

DISCALDIRTMAG

de-aerator - dirt separators



altecnic
Caleffi group

5461 DISCALDIRTMAG de-aerator-dirt separator



Application

Automatic dirt and air separators are used to continuously remove debris and air contained in the hydraulic circuits of heating and cooling systems.

They are capable of automatically removing all the air present in the system down to micro-bubble level, with very low head losses.

The large air collection chamber is able to accommodate a large volume of air before being released automatically.

At the same time they separate debris and impurities contained in the system which collect in the lower part of the collection chamber from which they may be expelled via the blowdown valve.

The Discal Dirtmag with the external clip on magnet is designed to attract and retain ferrous particles.

The circulation of fully de-aerated water enables equipment to operate under optimum conditions, free from any noise, corrosion, localised overheating or mechanical damage, important for reducing energy demands and on going running costs.

Design

The Discal dirt and air separator is manufactured from epoxy coated steel with a stainless steel internal element.

Suitable for installation in horizontal pipework.

Supplied with female parallel threaded end to BS EN ISO 228-1

Low pressure loss.

Supplied with a hose union ball blow down valve.

Supplied with hot preformed shell for thermal insulation.

Construction Details

Component	Material	Grade
Body	Steel - epoxy coated	
Automatic air vent body	Brass	BS EN 12165 CW617N
Internal element	Stainless Steel	
Float	Polypropylene	
Float guide	Brass	BS EN 12165 CW614N
Stem	Brass	BS EN 12165 CW614N
Float lever	Stainless steel	
Spring	Stainless steel	
Seals	EPDM	
Drain valve	Brass	BS EN 12165 CW617N

Dimensions

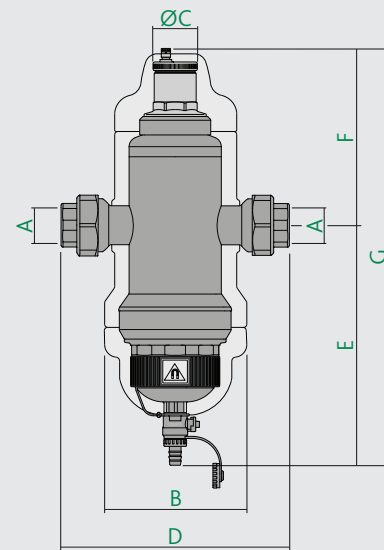

Prod Code	A	B	C	D	E	F	G	kg
546118	G1½	180	55	283	297	218.5	515.5	10
546119	G2	180	55	315	311	253.5	564.5	13

Technical Data

Medium:	water glycol solution
Max. percentage of glycol:	50%
Max. working pressure:	10 bar
Temperature range:	0 to 110°C
Particle separation rating:	up to 5µm
Ring magnet induction:	2 x 0.3

Technical Specification of Insulation Shell

Material:	Closed cell expanded PE-X
Thickness:	20mm
Density:	- inner part 30 kg/m³ - outer part 80 kg/m³
Thermal conductivity (ISO 2581):	at 0°C 0.038W/(m.K) at 40°C 0.045W/(m.K)
Coefficient of resistance to water vapour (DIN 52615):	> 1.300
Working temperature range:	0 to 100°C
Resistance to fire (DIN 4102):	class B2

External Layer - all sizes

Material:	embossed unfinished aluminium
Thickness:	0.7mm
Resistance to fire (DIN 4102)	class 1

5461 DISCALDIRTMAG de-aerator-dirt separator

Construction Details

The construction of the discal dirt and air separator allows it to be maintained and cleaned without removing it from the system.

The components that control the air venting are accessed by removing the cover (1).

The automatic air vent, located at the top of the dirt and air separator, is equipped with a long chamber for float movement (2). This feature prevents impurities in the water from reaching the seat.

When cleaning simply unscrew that part of the body containing the automatic air vent (3) to clean the entire air venting system.

Discal dirt and air separators have a collection chamber (4) equipped with a hose union ball shut-off valve (5) this means impurities can even be expelled while the system is in operation.

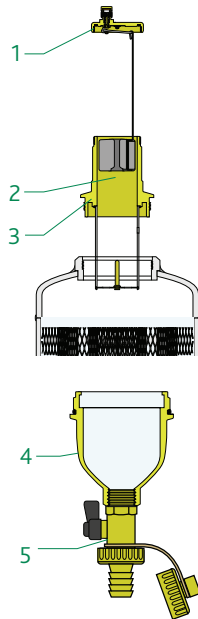

Operating Principles

Dirt and air separator use the combined action of several physical principles.

The active part consists of an assembly of concentric stainless steel mesh surfaces. These elements create the whirling movement required to facilitate the release of micro-bubbles and their adhesion to these surfaces.

The bubbles, fusing with each other, increase in volume until the hydrostatic thrust is such as to overcome the adhesion force to the structure.

They rise towards the top of the unit from which they are released through a float-operated automatic air release valve.

It is designed in such a way that the direction in which the medium is flowing inside it makes no difference.

Debris in the water, colliding with the internal element are separated out and fall to the bottom of the valve body.

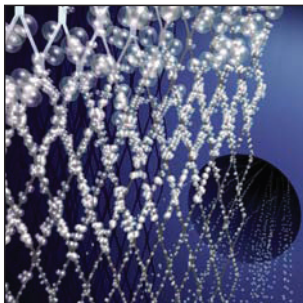

Solubility of Air in Water

The amount of air which can remain dissolved in a water solution is a function of pressure and temperature.

This relationship is governed by Henry's Law and the graph shows the physical phenomenon of the volume of air released by the fluid to be quantified.

As an example, at a constant absolute pressure of 2 bar, if the water is heated from 20°C to 80°C, the amount of air released by the solution is equal to 18 l per m³ of water.

According to this law it can be seen that the amount of air released increases with temperature rise and pressure reduction.

The air comes in the form of micro-bubbles, a fraction of a millimetre in diameter.

In circuits of air-conditioning systems there are specific points where this micro-bubble formation process takes place continuously: inside boilers and devices which operate under conditions of cavitation.

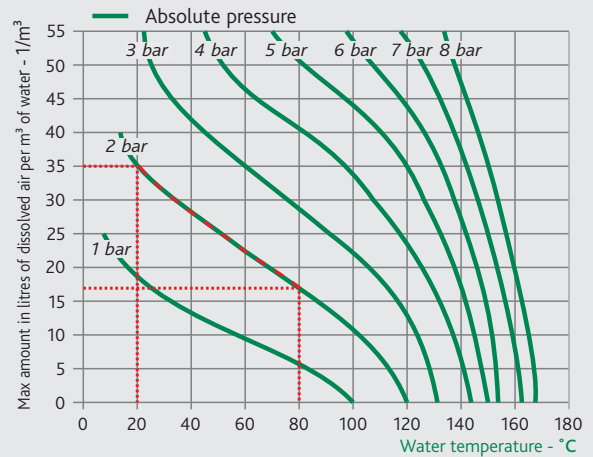

Boiler Micro Bubbles

Micro-bubbles form continuously on the surfaces separating the water from the combustion chamber due to the high temperature of the medium.

This air, carried by the water, collects at critical points of the circuit, from which it must be removed.

Some of it is reabsorbed where it meets colder surfaces

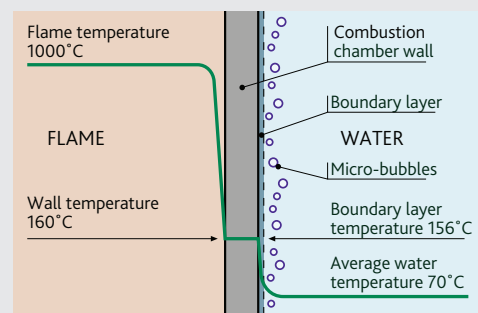

Cavitation Micro Bubbles

Micro-bubbles develop where the speed of the medium is particularly high, with a corresponding reduction in pressure. These points are usually the pump impellers and the water orifices of the regulating valves.

These micro bubbles of air, the formation of which is accentuated in non-de-aerated water, may subsequently implode as a result of the cavitation effect.

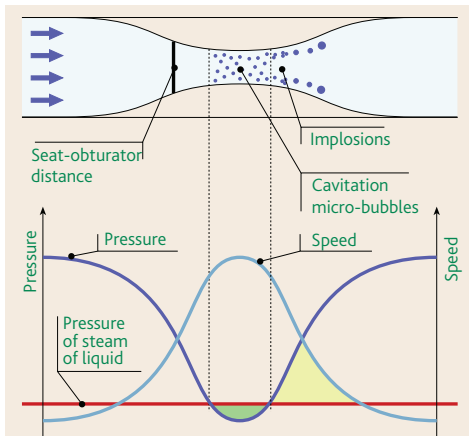

Dirt Separation Efficiency

The effectiveness of any device to separate and collect particles of debris from a flowing liquid depends upon:-

- 1 The larger the particles the more effective the device.
- 2 If the flow velocity reduces the particles separate and fall more easily.
- 3 The number of times the liquid re-circulates through the device.

The design of the discal dirt and air separator enables it to collect particles down to a minimum size of $5 \mu\text{m} = 0.005 \text{ mm}$.

The chart summarises tests conducted to illustrate how quickly particles are collected.

After only 50 circulations, approximately one day of operation, 100% of particles $100 \mu\text{m} = 0.1 \text{ mm}$ in size and approximately 80% of all particles had been collected.

Continued circulation gradually leads to the virtual removal of all particles.

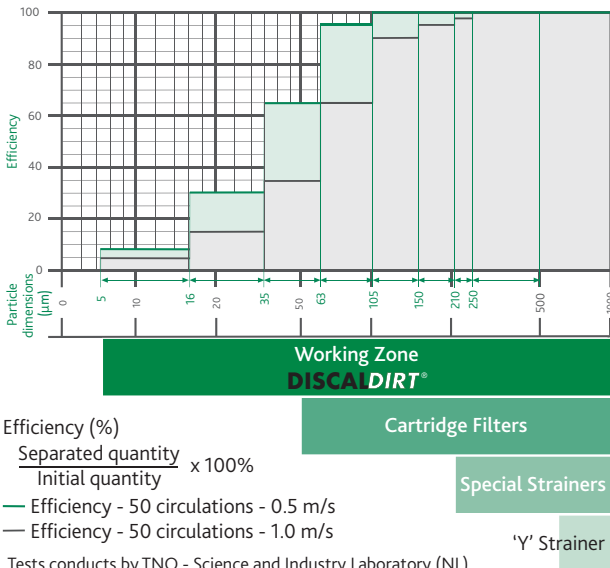

Pressure Loss Chart

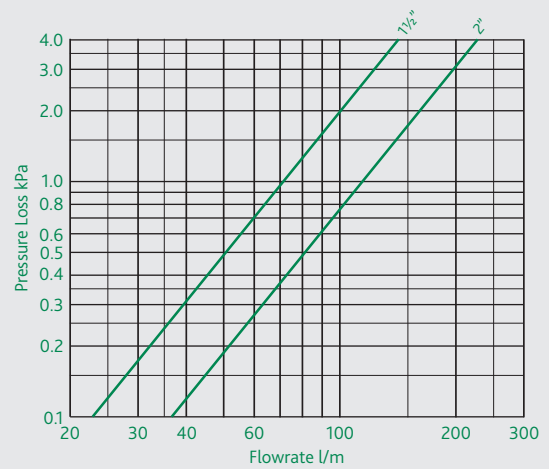

Size - in	1 1/2	2
Kv - m ³ /h	43.2	68.3

The maximum recommended flow velocity inside the pipe is 1.2 m/s. The following shows the maximum flow rates to meet this requirement.

Size - in	1 1/2	65
l/m	56.8	94.6

Based on BS EN 10255 steel pipe.

Lower Pressure Loss

A conventional 'Y' strainer performs its function via a mesh or perforated sheet element, the size of the holes selected determines the smallest particle size.

The strainer therefore has an initial pressure loss which increases as the basket fills, especially when more than half full.

The dirt separator functions by particles striking the element and dropping into the collection chamber.

The pressure loss is greatly reduced and is not affected by the amount of debris collected.

Note: Both devices require cleaning as part of a planned maintenance programme.

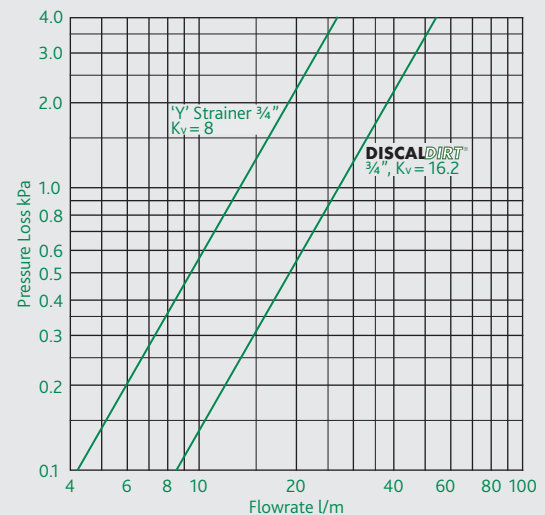

5461 DISCALDIRTMAG de-aerator-dirt separator

Installation

Discal dirt and air separators may be used in both heating and cooling systems, to ensure the progressive removal of air which is continuously formed.

The units should preferably be installed after the boiler and on the pump suction side, as these are the points where the formation of micro-bubbles is greatest.

Discal dirt and air separators must be installed in a vertical position, and preferably upstream of the pump where, due to the high speed of the medium and the ensuing drop in pressure, in this position air micro-bubbles develop more easily.

The flow direction of the medium is not important.

It is recommended that the vent cap is replaced with an Altecnic hydroscopic safety cap if the device is installed in a location that cannot be inspected.

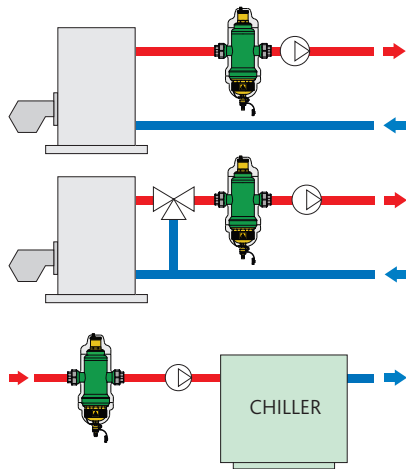
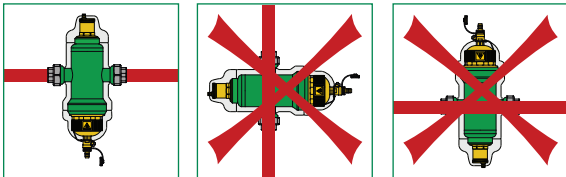

Insulation

Discal dirt and air separators are supplied complete with hot pre-formed shell insulation.

This system ensures not only perfect thermal insulation, but also the tightness required to prevent atmospheric water vapour from entering the unit.

For this reason, this type of insulation may also be used in cooling water circuits as it prevents condensation from forming on the surface of the valve body.

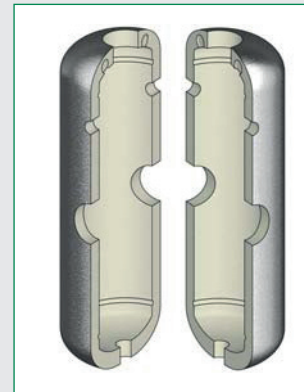

5461 DISCALDIRTMAG de-aerator-dirt separator

Typical Application

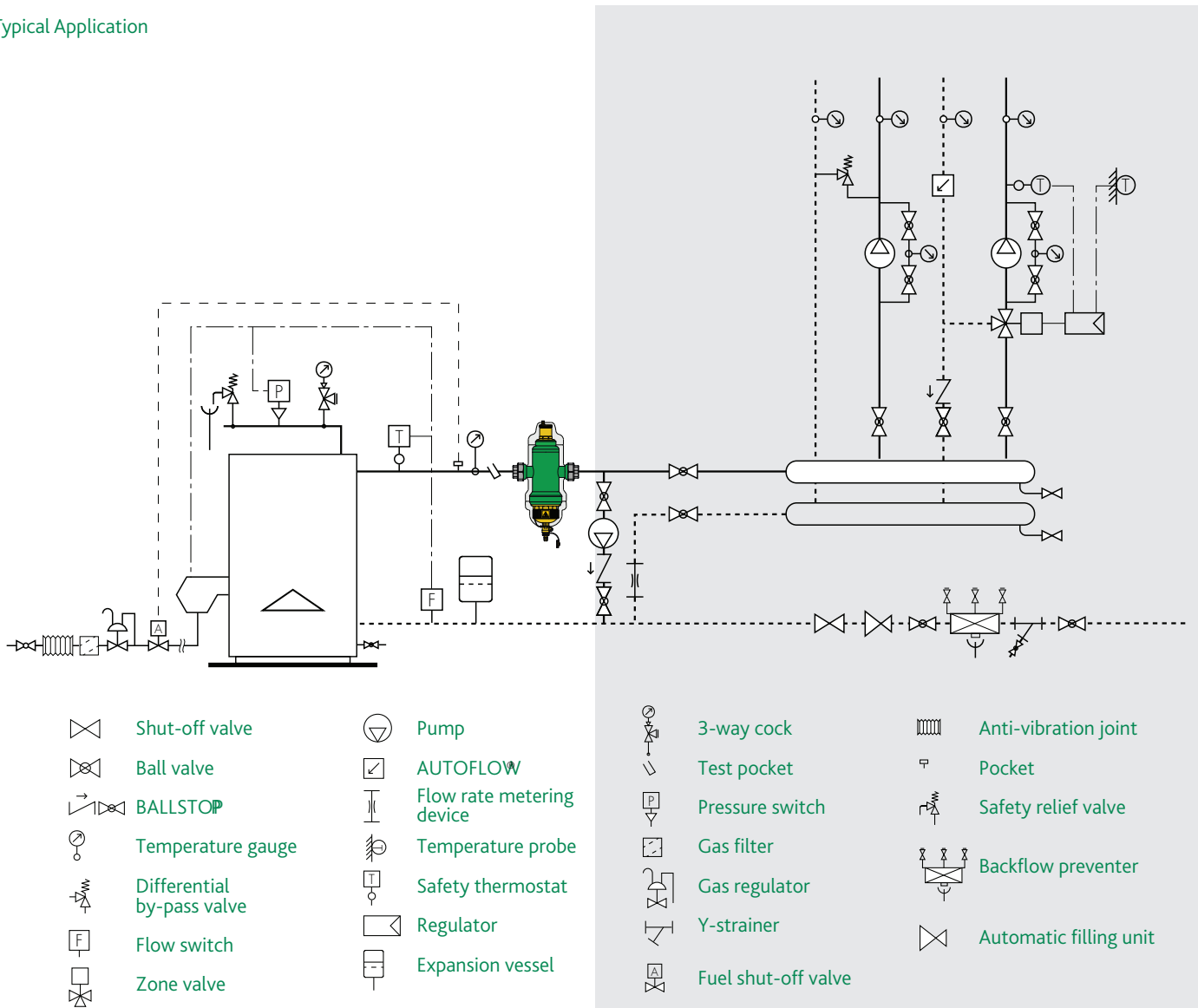

Altecnic Ltd Mustang Drive, Stafford, Staffordshire ST16 1GW

T: +44 (0)1785 218200 E: sales@altecnic.co.uk

Registered in England No: 2095101

altecnic.co.uk

AL 323 27-11-18

E & O.E

© Altecnic Limited. 2018

ALTECNIC™