

# AI-057 dzt

double & single check valves



altecnic

# AI-057 dzr double & single check valves



## Application

The Altecnic single and double check valves are used to prevent the risk of backflow and back siphonage contamination in domestic dwellings, public and commercial buildings.

The valves should be installed close to the water outlet such as taps, basin taps, showers and toilets to prevent back siphonage contamination to the water supply, should a mains supply pipe burst.

## Design

The Altecnic single check valve complies with BS EN 13959 'Anti-pollution check valves' family EA - verifiable single check valve.

The Altecnic double check valve complies with BS EN 13959 'Anti-pollution check valves' family EC - verifiable double check valve

The single check valve provides category 2 and the double check valve provides category 3 protection for both backflow and back siphonage as specified in the Water Supply (Water Fittings) Regulations 1999.

The Altecnic check valves are manufactured from DZR copper alloy, the single check has a brushed chrome plated finish and the double check a nickel plated finish, to enhance the appearance for exposed installations.

The valves provide category 3 protection for both backflow and back siphonage as specified in the Water Supply (Water Fittings) Regulations 1999.

The double check valve is supplied with an integral test point for monitoring the function of the downstream check valve.

The valves are designed for high flow rates with minimum pressure drops.

Supplied with female inlet and male outlet threads complying with BS EN ISO 228-1.

## Construction Details

Component	Material	Grade
Body	DZR copper alloy	BS EN 12165 CW602N
Cartridge	POM	
Cartridge Retaining Clip	Stainless steel	AISI 302
Test Plug	DZR copper alloy	BS EN 12164 CW602N
'O' ring	EPDM	

Product code	Size	Valve Type	Connections
AI-05731480	3/4"	single check	male x female
AI-05794940	3/4"	double check	male x female

## Dimensions

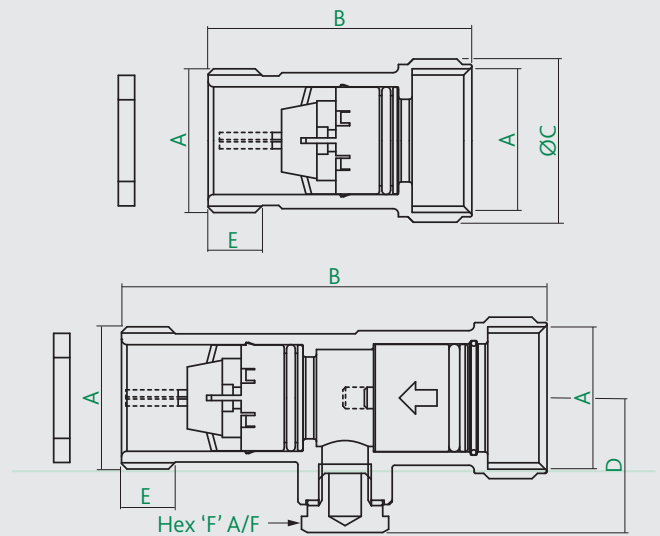

Product Code	A	B	C	D	E	F	kg
AI-05731480	G3/4	48.5	30	-	10	-	0.085
AI-05794940	G3/4	79	30	25	10	17	0.140

## Technical Data

Test pressure:	15 bar
Max operating pressure:	10 bar
Min operating pressure:	0.2 bar
Max operating temperature:	60°C
Conforms to:	BS EN 13959
WRAS approved product	

## Pressure/Temperature Chart

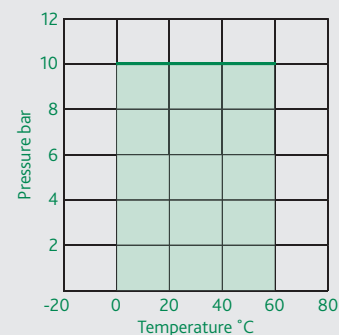

## Installation

The valves are very simple to install with just two joints to make.

The flow through the valves must follow the direction arrow on the valve body.

© Patents & Design Altecnic 2019

Altecnic Ltd retains all rights (including patents, designs and copyrights, trademarks and any other intellectual property rights) in relation to all information provided on or via the website, brochures or any other documents, including all texts, graphics and logos, contained on the website, in brochures or in any other documents published in the name of or on behalf of Altecnic Ltd in any form, without prior written consent of Altecnic Ltd.

Altecnic Ltd Mustang Drive, Stafford, Staffordshire ST16 1GW

T: +44 (0)1785 218200 E: sales@altecnic.co.uk

Registered in England No: 2095101

altecnic.co.uk

AL 353 18-12-19

E & O.E

© Altecnic Limited. 2019

ALTECNIC™

altecnic