

116

thermostatic regulator with
built-in check valve

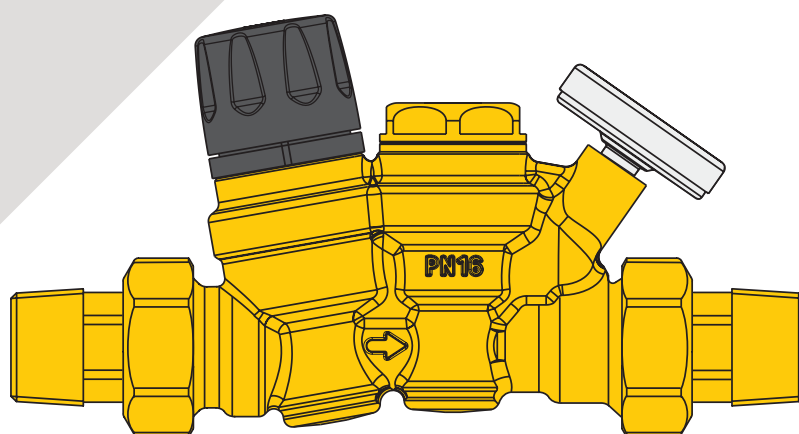

altecnic
CALEFFI group

116 thermostatic regulator with built-in check valve

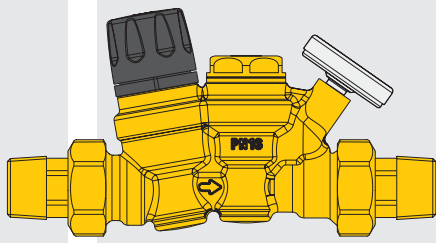

Introduction

The Altecnic thermostatic regulator for domestic hot water re-circulation systems automatically maintains the specified water temperature.

Function

The thermostatic regulator is intended to be installed in the return pipe of each re-circulation circuit, automatically maintaining the specified water temperature.

The regulator controls the flow rate in accordance with the inlet water temperature by means of a dedicated internal thermostatic cartridge.

When the water temperature approaches the set value, the obturator progressively close and reduces the flow passage reducing the amount of water re-circulating.

The water supplied by the re-circulation pump is available to be distributed to other branches in the system, resulting in effective automatic thermal balancing.

The regulator is equipped with single check valve and a thermal disinfection function, which is useful if the water temperature exceeds 55 to 60°C

Product Range

Ref No	Description
116144	½" regulator with probe pocket for temperature gauge
116154	¾" regulator with probe pocket for temperature gauge
116244	½" regulator with temp. gauge and disinfection cartridge
116254	¾" regulator with temp. gauge and disinfection cartridge

Construction Details

Component	Material	Grade
Body:	DZR	BS EN 12165 CW724R
Adjustable cartridge:	Polymer	PSU
Seals:	Elastomer	EPDM
Adjustment knob:	Polymer	ABS
Springs:	Stainless St	BS EN 10270-3 (AISI 302)
Check valve:	Polymer	PPO/GF
Check valve spring:	Stainless St	BS EN 10270-3 (AISI 302)
Check valve seal:	Elastomer	EPDM

Technical Specification

Kv max.:	1.8 m ³ /hr
Kv dis.:	1.0 m ³ /hr
Kv Min.:	¾" (58°C) 0.2±20%
Kv (Δt=5K):	0.45 m ³ /hr
Max. working pressure:	16 bar
Max. differential pressure:	1 bar
Adjustable temperature range:	35 to 60°C
Factory setting:	52°C
Min. inlet temperature:	90°C
Disinfection temperature:	70°C
Closing temperature:	75°C

Dimensions

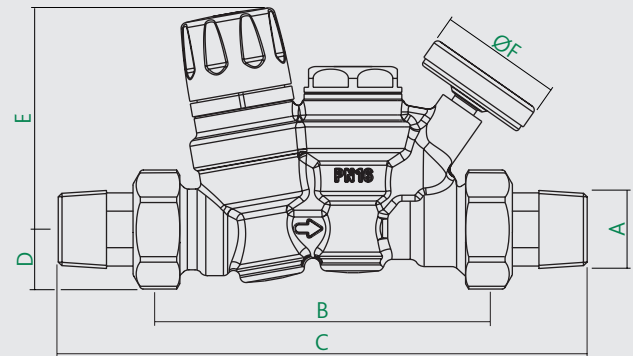

Ref No	A	B	C	D	E	ØF
116144	R½				74.5	41
116154	R¾				74.5	41
116244	R½				74.5	41
116254	R¾				74.5	41

Typical Installation

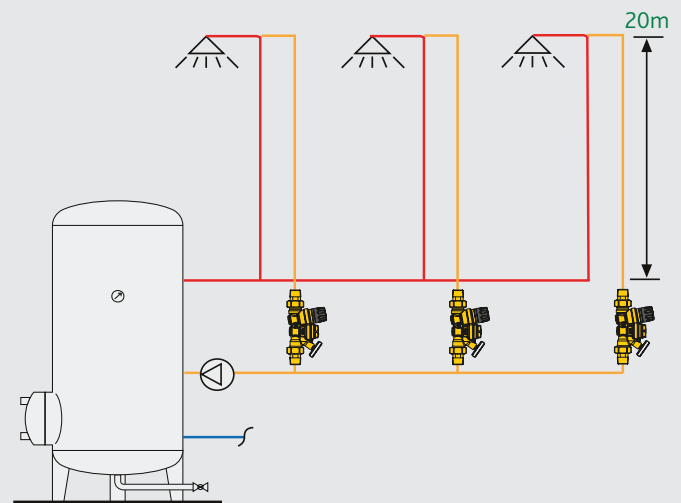

Construction - 116244 and 116254 with cartridge for disinfection and temperature gauge

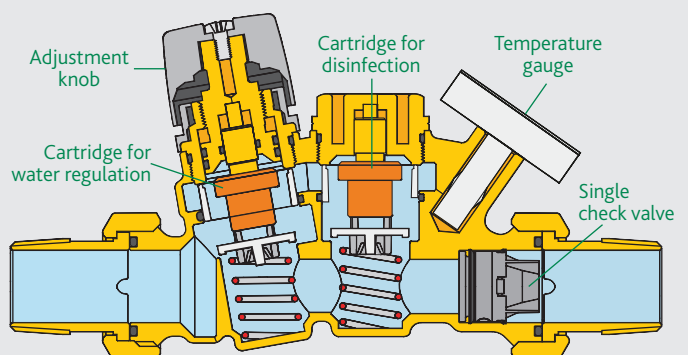

116 thermostatic regulator with built-in check valve

Regulating Characteristics

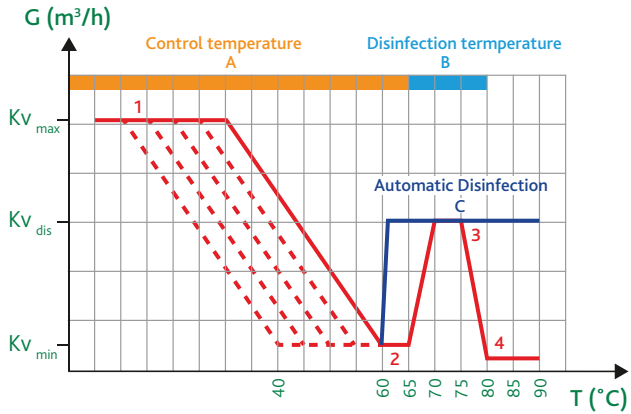

- A = control temperature range
- B = control temperature range for automatic disinfection
- C = control temperature range for manual disinfection using the electric actuator and manual cartridge

Operation

1 Control Temperature Range

On reaching the set temperature, the obturator (1), governed by the thermostatic sensor (2), modulates the closure of the hot water outlet (3), thereby aiding circulation towards the other connected circuits.

As the temperature approaches 65°C the obturator enters fully into the seat bore and this is the minimum open position.

In this position the valve does not isolate the flow but allows a small flow through the seat to maintain hot water re-circulation.

If the temperature decreases, there is the opposite action and the passage reopens, so as to ensure that all the branches of the system reach the required temperature. The characteristic curve of the valve is shown above curve A.

2 Disinfection Flow Path

The characteristic curve of operation B is the same as curve A until a temperature higher than 68°C is reached.

At this value the second thermostatic sensor (5) intervenes with the aim of controlling the disinfection process, allowing circulation independently of the action of the first thermostat. This allows a passage of medium through a special by-pass (4), opening a passage up to the temperature of 70°C. If the temperature rises beyond this value, the flow through the by-pass circuit is reduced so as to allow thermal balancing to be performed even during the disinfection process.

The characteristic curve of the valve is shown above curve A+B.

3 Closed Position During Disinfection

When the temperature reaches approximately 75°C, the regulator reduces the obturator to its minimum position open (6) and minimum flow rate so as not to circulate water at too high a temperature.

The characteristic curve of the valve is shown in fig. F, curve A+C.

Operation

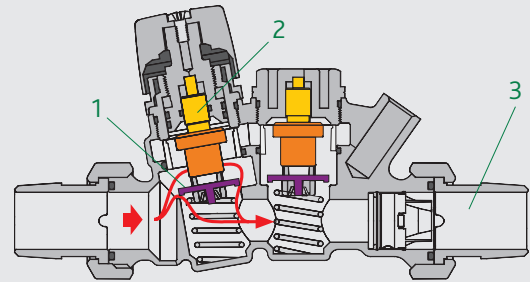

1 Control temperature position open

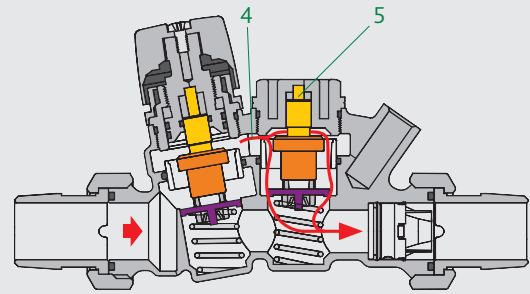

2 Disinfection flow path

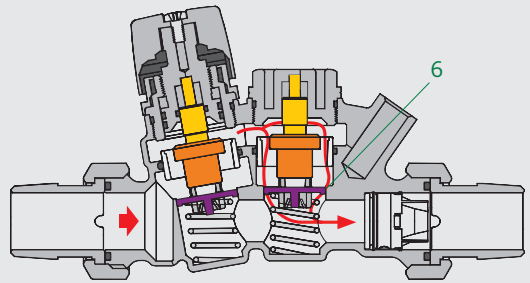

3 Closed position during disinfection

116 thermostatic regulator with built-in check valve

Fitting the Electric Actuator

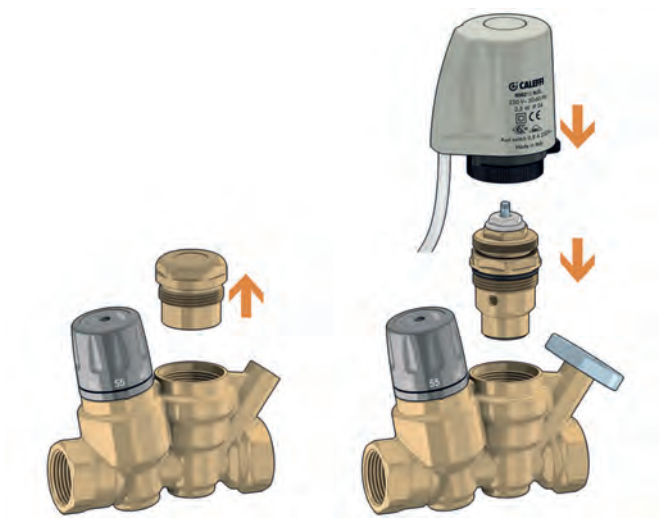

Accessories



Product code - thermo-electric actuator

116002	240V electric actuator
116004	24V electric actuator

Technical Specification

Normally closed ON/OFF:

Electric supply:	230V ac - 24 V ac
Power consumption:	1.8 W
Insulation:	class II
Protection class:	IP 54
Ambient temperature range:	0 to 60°C
Operating time:	150 to 200 seconds
Length of cable:	1 metre

Accessories



Cartridge for use with electric actuator

© Patents & Design Altecnic 2023

Altecnic Ltd retains all rights (including patents, designs and copyrights, trademarks and any other intellectual property rights) in relation to all information provided on or via the website, brochures or any other documents, including all texts, graphics and logos, contained on the website, in brochures or in any other documents published in the name of or on behalf of Altecnic Ltd in any form, without prior written consent of Altecnic Ltd.

Altecnic Ltd Mustang Drive, Stafford, Staffordshire ST16 1GW

T: +44 (0)1785 218200 E: sales@altecnic.co.uk

Registered in England No: 02095101

altecnic.co.uk

AL 500 14-12-23

E & O.E

© Altecnic Limited. 2023

ALTECNIC™

altecnic
CALEFFI group