

# PV016E

expansion vessel



altecnic

# PV016E expansion vessel



## Introduction

If the pressure in a system is high, the water when flowing has a greater momentum which when brought to a sudden halt, will create a shock effect causing pipes to shudder and vibrate.

This is normally caused by the rapid closure of lever operated taps or valves, solenoid valves or valves in dish washers and washing machines.

The Altecnic stainless steel expansion vessel can be used as a water hammer arrester intended for a single outlet, such as a tap or washing machine, or a small group of outlets, such as in a bathroom.

The vibration caused by water hammer is not only annoying but eventually can result in split or cracked pipe fittings, especially at joints.

The expansion vessel should be installed close to the tap or valve minimising the effect of the shock on the system.

This expansion vessel is suitable for use in coastal environments and with brackish water due to its stainless steel construction.

## Operating Principle

The expansion vessel consists of a pressure vessel, divided into two chambers by a flexible rubber membrane or diaphragm.

The closed chamber is filled with air, pressurised to 3.5 bar, which acts as a damper due to the compressibility of the trapped air.

The open chamber is connected directly to the system and is filled with water.

When a pressure surge occurs, the compression of the air counteracts the thrust on the rubber membrane allowing a small change in volume which absorbs the excess pressure.

## Typical Applications

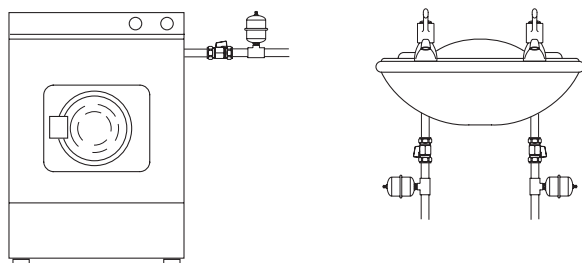

## Dimensions

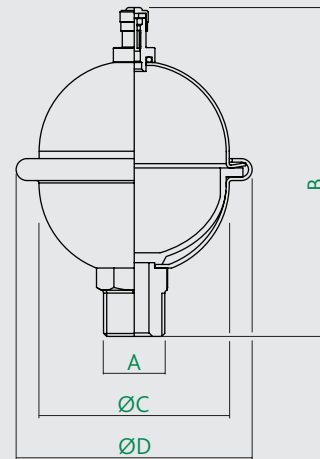

Ref No	A	B	C	ØD	kg
PV016E	G½	95	61	77	0.204

## Construction Details

Components	Material	Grade
Upper body:	Stainless steel	AISI 304
Lower body:	Stainless steel	AISI 304
Membrane:	Synthetic butyl elastomer	
Connector:	Stainless steel	AISI 304

## Technical Specification

Medium:	Water
Max. working pressure:	15 bar
Max. system temperature:	100°C
Pre-charge pressure:	3.5 bar - air
Connection:	G½
PED:	97/23/EC

Product Code	Volume	Connection
PV016E	0.16 litre	threaded

## Service and Maintenance

Altecnic recommend that the air pressure is checked annually and adjusted if necessary.

This can be done using an air pressure gauge and foot pump.

© Patents & Design Altecnic 2025

Altecnic Ltd retains all rights (including patents, designs and copyrights, trademarks and any other intellectual property rights) in relation to all information provided on or via the website, brochures or any other documents, including all texts, graphics and logos, contained on the website, in brochures or in any other documents published in the name of or on behalf of Altecnic Ltd in any form, without prior written consent of Altecnic Ltd.

Altecnic Ltd Francesco House, Staples Close, Stafford ST16 1WQ

T: +44 (0)1785 218200 E: sales@altecnic.co.uk

Registered in England No: 02095101

altecnic.co.uk

AL 515 06-01-25

E & O.E

© Altecnic Limited. 2025

ALTECNIC™