

545912

under boiler magnetic filter



altecnic
CALEFFI group

545912 under boiler magnetic filter



Introduction

The Altecnic under-boiler magnetic filter mechanically separates the impurities in heating and cooling systems by means of a mesh filter, a neodymium magnet and a collection chamber for the heaviest particles.

The chamber has transparent windows, allowing the user to check whether the internal elements need to be cleaned.

It's small dimensions make it suitable most types of boiler of heat interface unit (HIU).

Construction Details

Component	Material	Grade
Body:	Brass	BS EN 12165 CW617N
Compression nut:	Brass	BS EN 12165 CW617N
Seals:	Elastomer	EPDM
Filter container:	Polymer	PA 12
Magnet holder cap:	Polymer	PA6G30
Filter:	St steel	AISI 304

Technical Specification

Medium:	water, glycol solution
Max. percentage of glycol:	30%
Max. working pressure:	3 bar
Working temperature range:	0 to 90°C
Filter mesh:	800 µm
Magnetic induction of magnet:	0.475 T
Kv:	3.66 m ³ /h
Connections:	22 mm compression

Pressure Loss Chart and Kv Value

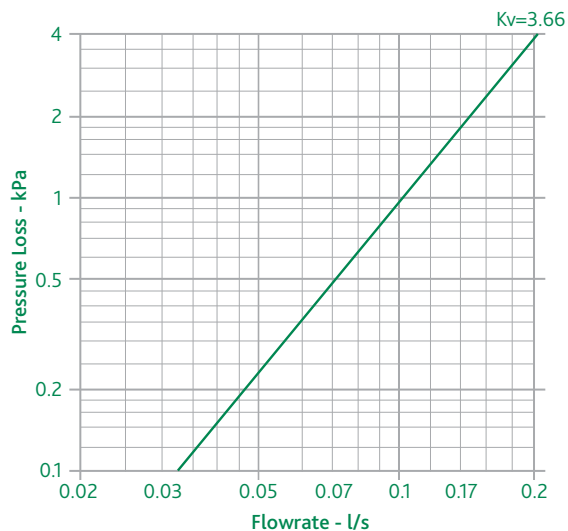

Dimensions

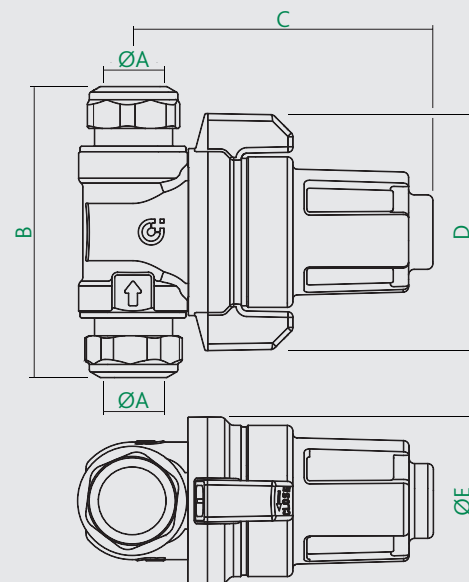

Ref No	ØA	B	C	D	ØE	kg
545912	22	104.4	107.6	85	60	0.75

Operating Principles

The magnetic filter operation is based on three principles;

- the mechanical filtration provided by the steel mesh captures the impurities
- the magnetic field separates ferrous particles
- a large separating chamber allows the dirt to settle

The special deflector profile directs impurities in the water and makes them precipitate in the separating chamber, where they are collected.

The magnet, which is positioned so that the flow hits it head-on, effectively separates the ferrous particles.

The 800 µm filter mesh captures the remaining impurities.

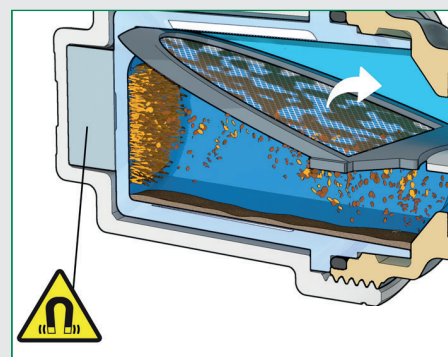

545912 under boiler magnetic filter

Operating Principles - Isolation Valve

The isolation valve has been specially designed so that only the water contained in the dirt separator needs to be drained before cleaning the internal elements.

To isolate the filters the closing collar must be turned counter-clockwise.

Caution! Do not force valve closure in the wrong direction.

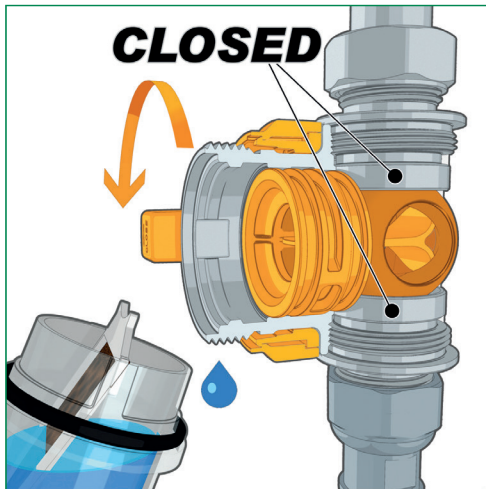

Construction Details

The collection chamber has transparent windows, so it is easy to check if the internal elements need to be cleaned.

Only clean the chamber when strictly necessary.

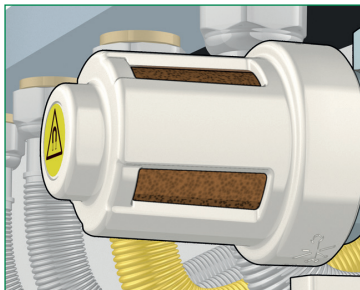

Neodymium Magnet

The neodymium magnet is positioned so that the metal particles are strongly attracted. The magnet is not in direct contact with the medium, making it easy to clean.

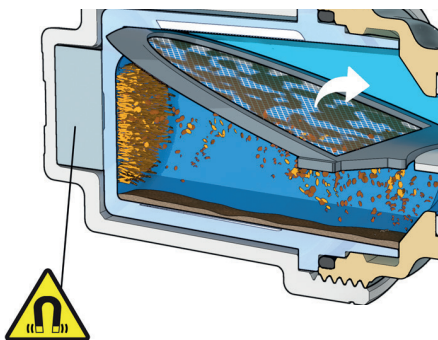

Installation

The magnetic filter must be installed with the flow in the same direction as the integral flow arrow cast in the body.

The magnetic filter is installed under the boiler or heat interface unit normally with the flow from below.

The filter chamber must be installed horizontally (as shown) or vertically below the body of the filter.

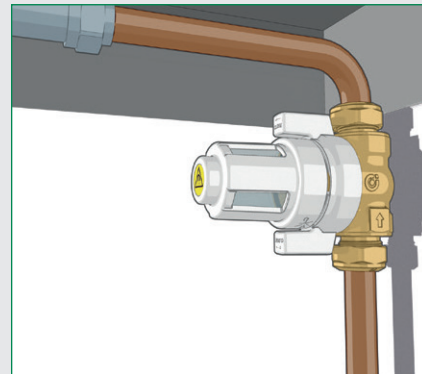

Maintenance

After checking the dirt separator for debris, it can be cleaned with a few simple steps.

- Cleaning must be carried out with the boiler turned OFF, with water temperature at ambient and at atmospheric pressure.
- Isolate the filter by using the dedicated ball valve and unscrewing the outer cover.
- Pull away the filtering cartridge from the filter body and remove the filter.
- The filtering cartridge can be washed with running water.

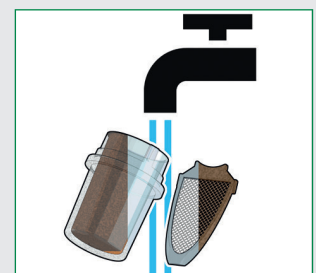
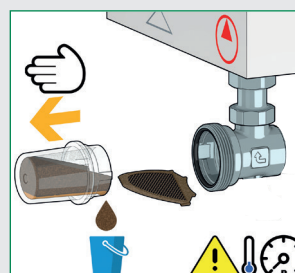
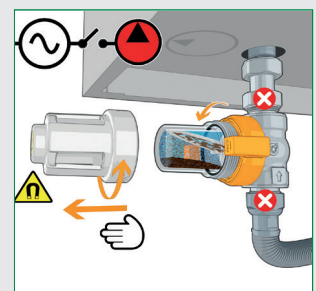

Accessories

A flushing kit is available to use the filter to flush the system and as an injection point for chemical additives - [Code F0001037](#)

545912 under boiler magnetic filter

© Patents & Design Altecnic 2025

Altecnic Ltd retains all rights (including patents, designs and copyrights, trademarks and any other intellectual property rights) in relation to all information provided on or via the website, brochures or any other documents, including all texts, graphics and logos, contained on the website, in brochures or in any other documents published in the name of or on behalf of Altecnic Ltd in any form, without prior written consent of Altecnic Ltd.

Altecnic Ltd Francesco House, Staples Close, Stafford ST16 1WQ

T: +44 (0)1785 218200 E: sales@altecnic.co.uk

Registered in England No: 02095101

altecnic.co.uk

AL 485 23-01-25

E & O.E

© Altecnic Limited. 2025

ALTECNIC™

altecnic
CALEFFI group