

COMPACT WALL MOUNTED
HEAT INTERFACE UNIT
INSTANTANEOUS DHW PRODUCTION ONLY
40 PLATE EXCHANGER

altecnic
CALEFFI group

SATK10255 HIU



Functions and Features

- Wall-mounted HIU instantaneous domestic hot water production
- Design ready to install a compact heat meter with 1" threaded connections and 130 mm overall length
- Domestic water maximum flow rate 27 l/m
DHW temperature range 42 to 60°C
16 plate heat exchanger
- Electronic regulator with LED indicator, Reset key, trimmers, LED display and DIP switches
- Compact size, simple installation, use and maintenance
Designed for installation behind a panel
- Error codes associated with faults shown on the LED display



Dimensions

Overall Dimensions: W 476 x H 350 x D 188

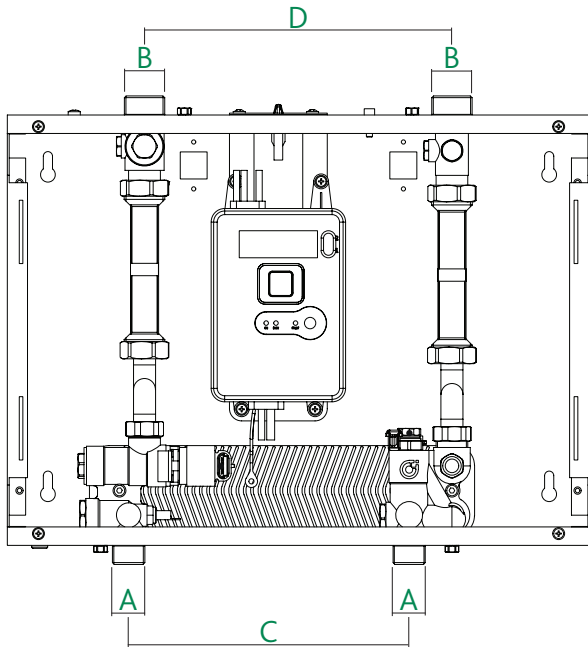

A	B	C	D
G $\frac{3}{4}$ M	G1 M	230	252

Technical Specification

Maximum medium temperature:	85°C
Maximum working pressure: - primary circuit:	10 bar
- domestic water circuit:	10 bar
DHW production range:	42 to 60°C
Primary circuit nominal flow rate:	1.3 m ³ /hr
Nominal headloss on primary circuit:	Δp 30 kPa
Max. head on primary circuit:	Δp 90 kPa
Domestic water circuit max. flow rate:	27 l/m
Min. flow to activate domestic water meter:	2.7 l/m
Max. Power consumption:	20 W
Protection class:	IP 40
Actuators:	stepper 24 V
Probe:	NTC 10 k Ω

Electronic Regulator

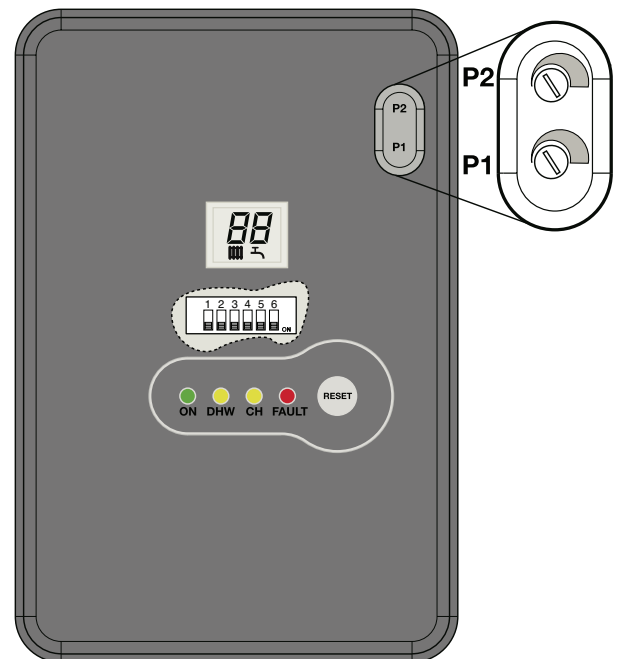

© Patents & Design Altecnic 2025

Altecnic Ltd retains all rights (including patents, designs and copyrights, trademarks and any other intellectual property rights) in relation to all information provided on or via the website, brochures or any other documents, including all texts, graphics and logos, contained on the website, in brochures or in any other documents published in the name of or on behalf of Altecnic Ltd in any form, without prior written consent of Altecnic Ltd.

Altecnic Ltd Francesco House, Staples Close, Stafford ST16 1WQ

T: +44 (0)1785 218200 E: sales@altecnic.co.uk

Registered in England No: 02095101

altecnic.co.uk

AL 483 23-01-25

E & O.E

© Altecnic Limited. 2025

ALTECNIC™