

359

domestic manifolds

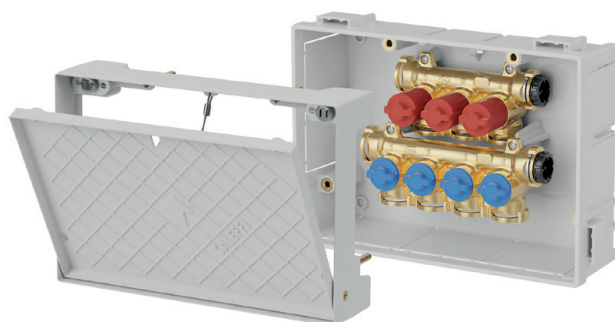
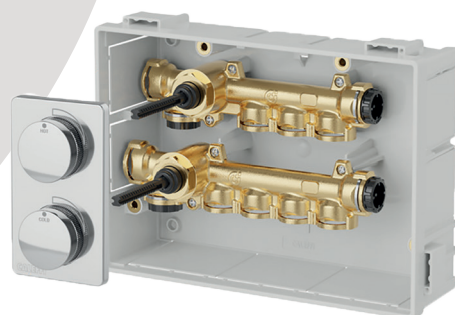

altecnic
CALEFFI group

359 domestic manifolds

Distribution Manifolds with Individual Isolation Valves

Function

The distribution manifolds with individual isolation valves are used to control and distribute water in domestic water circuits.

They are supplied already assembled in a plastic inspection box to facilitate positioning and installation.

They are equipped with isolation valves with a handwheel for each individual circuit and an identification number for the user served.

Box installation can be completed using push-to-open inspection ports or aesthetic cover plates that are available in different finishes.

Product range

| Ref No | Description |
|--------|--|
| 359410 | Manifold with individual isolation valves (4+3) |
| 359510 | Manifold with individual shut-off valves (5+4) |
| 359700 | Recessed inspection port with push-to-open frame |
| 359801 | Plastic aesthetic cover plate (white) |
| 359802 | Stainless steel aesthetic cover plate (shiny finish) |
| 359903 | Stainless steel aesthetic cover plate (brushed finish) |

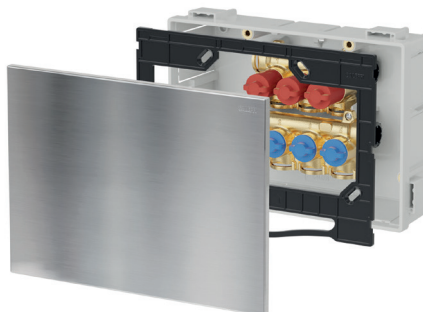
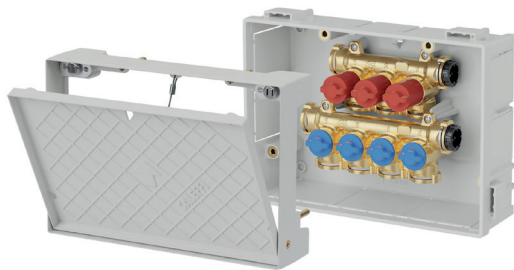

Distribution Manifolds with Main Isolation Valves

Function

The distribution manifolds with main isolation valves are equipped with isolation valves on the hot and cold inlets.

They are also equipped with an outlet upstream of the isolation valve which can be used for connection of the recirculation circuit.

Box installation is completed using a finishing plate with hidden knobs.

Product range

| Ref No | Description |
|--------|--|
| 359420 | Manifold with main isolation valves (4+3) |
| 359902 | Plate with hidden knobs (polished chrome finish) |

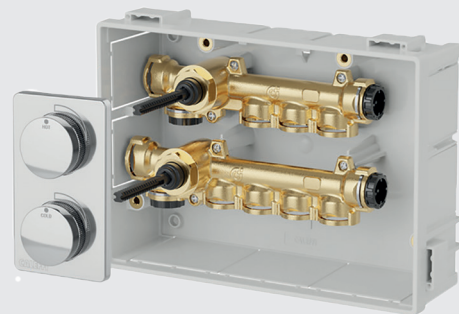

Unit with Main Isolation Valves

Function

The unit with main isolation valves is only equipped with inlet valves.

It allows maximum installation flexibility, as it is designed for connection of recirculation circuits and for the creation of various types of domestic water distribution.

Box installation is completed using a finishing plate with hidden knobs.

Product range

| Ref No | Description |
|--------|--|
| 359100 | Unit with main isolation valves |
| 359902 | Plate with hidden knobs (polished chrome finish) |



359 domestic manifolds

Dimensions

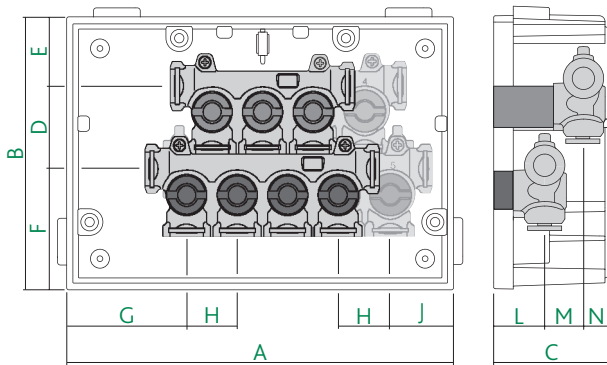

| Ref No | A | B | C | D | E | F | G |
|---------|-----|-----|----|----|----|-----------|----|
| 359410* | 270 | 190 | 80 | 57 | 47 | 86 | 82 |
| 359510* | H | J | L | M | N | kg | |
| | 35 | 47 | 35 | 27 | 18 | 2.5 / 2.8 | |

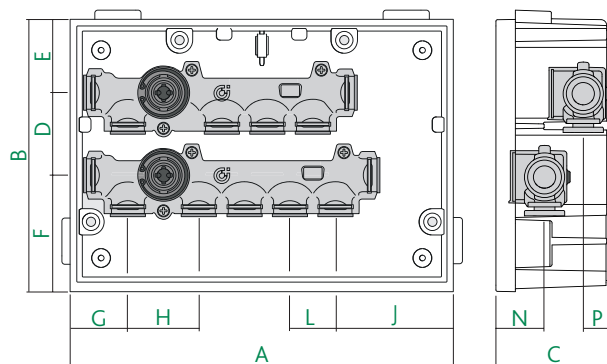

| Ref No | A | B | C | D | E | F | G |
|---------|-----|-----|----|----|----|-----|----|
| 359420* | 270 | 190 | 80 | 58 | 52 | 80 | 29 |
| | H | J | L | N | P | kg | |
| | 50 | 83 | 32 | 34 | 19 | 2.3 | |

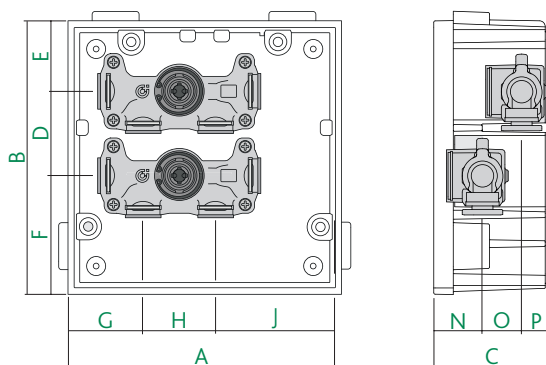

| Ref No | A | B | C | D | E | F | G |
|---------|-----|-----|----|----|----|-----|----|
| 359100* | 190 | 190 | 80 | 58 | 49 | 82 | 29 |
| | H | J | N | O | P | kg | |
| | 50 | 87 | 34 | 27 | 19 | 1.7 | |

Dimensions

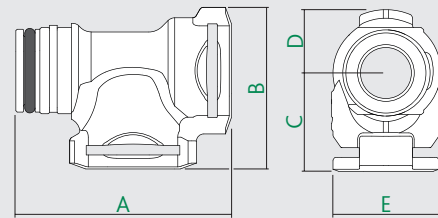

| Ref No | A | B | C | D | E | kg |
|---------|----|----|----|----|----|------|
| 359001* | 57 | 43 | 26 | 17 | 29 | 0.12 |

Materials

Body:

| | | |
|----------------------------|---------------------|---------------------|
| 359410, 359510, 359100: | brass | BS EN 12165 CW617N |
| 359410 001, 359510 001 | | |
| 359420 001: | Low Lead, DZR alloy | BS EN 12165 CW 724R |
| Isolation cartridge: | | PPSU |
| Seals: | | EPDM |
| Individual isolation knob: | | PA6G30 |
| Brackets: | | PP |

Box:

| | |
|-----------------|-----|
| Inspection box: | ABS |
|-----------------|-----|

Performance

| | |
|---|------------------------|
| Medium: | Potable water |
| Maximum working pressure: | 10 bar |
| Working temperature range: | 5 to 90°C |
| Main connections: | adaptor + fixing clip |
| Outlet connections: | adaptor + fixing clip |
| Outlet centre distance: | 35 mm |
| Average Internal diameter: | 15 mm |
| Individual isolation valve Kv: | 3.2 m ³ /hr |
| Main isolation valve Kv: | 7.0 m ³ /hr |
| Coefficient of localised loss ξ through outlet: | 3 |
| (versions with main isolation valves) | |

* versions in "LOW LEAD" dezincification resistant alloy,



Ref No add: 001 eg 359410 001

359 domestic manifolds

Related Standards

BS EN 806-3 "Specification for installations inside buildings conveying water for human consumption. Pipe Sizing - Simplified method."

Nominal Sizing Parameters

| Appliance | Flow rate l/s |
|--|---------------|
| Wash basin | 0.1 |
| Bidet | 0.1 |
| WC | 0.1 |
| Bathtub | 0.4 |
| Shower | 0.2 |
| Kitchen sink | 0.2 |
| Washing machine / domestic dish washer | 0.2 |

| Maximum recommended velocities | m/s |
|--|----------|
| Primary distribution, risers, floor distribution | 3 |
| Supply line to individual users | 4 |
| Recirculation system | 0.5 to 1 |

| Pressure conditions | bar |
|--|-------|
| Static pressure at the draw off point | max 5 |
| Dynamic pressure at the draw off point | min 1 |

Sizing Example

When the flow rates of the appliances are known, the pipe diameters can be sized. We suggest using multi-layer pipes.

The length of pipes inside the room is used to calculate the volume of hot water contained within the pipes.

If the water contained is greater than 3 litres, a recirculation circuit must be provided.

To guarantee the minimum pressure of 1 bar for the most disadvantaged appliance, the manifold/unit inlet pressure must be determined. It is therefore necessary to calculate the overall pressure drop. In the case in question, the most disadvantaged appliance is the shower.

CASE A

Distribution manifolds with individual and main isolation valves

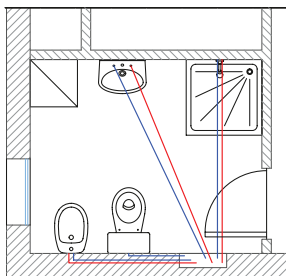

- Wash basin Ø 16 x 2
- Bidet Ø 16 x 2
- WC Ø 16 x 2
- Shower Ø 16 x 2

Calculation of the hot water volume

| | |
|------------|---------------|
| Internal Ø | 12 mm |
| Total L | 10 m |
| Volume | 1.151 l (<3l) |

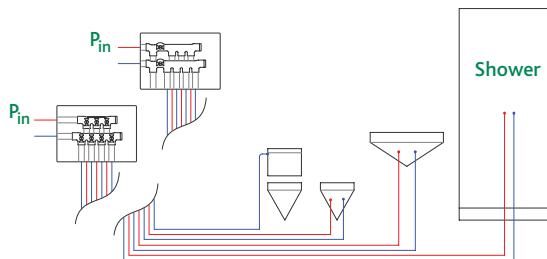

Manifold with individual isolation valves

$$P_{in} = P_{app\ sf} + \Delta P_d + \Delta P_c + \Delta P_{vis}$$

Manifold with main isolation valves

$$P_{in} = P_{app\ sf} + \Delta P_d + \Delta P_{vig} + \Delta P_{der}$$

P_{in} = pressure at inlet

$P_{app\ sf}$ = disadvantaged appliance minimum pressure

ΔP_d = Distribution pressure drop

ΔP_c = elbow pressure drop

ΔP_{vis} = individual isolation valve pressure drop

ΔP_{vig} = main isolation valve pressure drop

ΔP_{der} = outlet pressure drop

$\Delta P_{c,T}$ = T connection pressure drop

$$\Delta P_{c/der/c,T} = \xi \times \rho \times v^2 / 2 / 10^5 \text{ (bar)} \quad \Delta P_d = r \times L / 10^5 \text{ (bar)}$$

ξ = pressure drop coefficient r = pressure drop per unit length

ρ = density (kg/m³) (Pa/m)

v = velocity (m/s) L = length of pipes (m)

$$\Delta P_{vis/vig} = G^2 / Kv^2 \text{ (bar)}$$

G = flow rate (m³/hr) Kv = flow rate (m³/h) @ ΔP (1 bar)

CASE B

Unit with main isolation valves

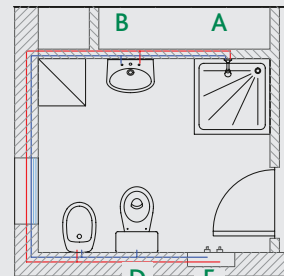

- AB Ø 16 x 2
- BC Ø 16 x 2
- CD Ø 16 x 2
- DE Ø 16 x 2

Calculation of the hot water volume

| Connection | T | Loop |
|------------|-------------|-------------|
| Internal Ø | 12 mm | 12 mm |
| Total L | 8 m | 16 m |
| Volume | 0.9 l (<3l) | 1.8 l (<3l) |

In-line distribution with T connection

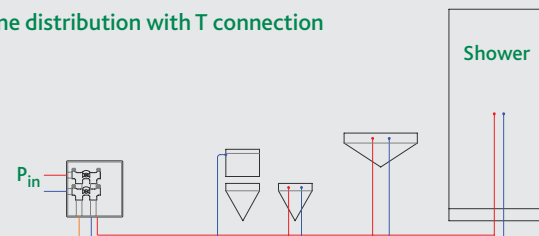

$$P_{in} = P_{app\ sf} + \Delta P_d + \Delta P_c + \Delta P_{vig} + \Delta P_{c,T} + \Delta P_{der}$$

Circulating loop distribution

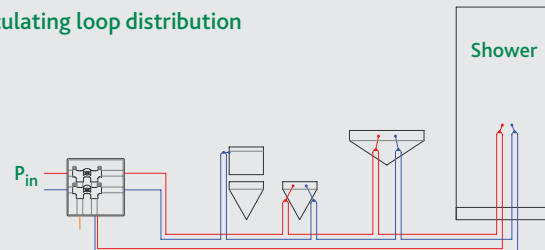

For a detailed calculation of the pressure drops within the loop circuit, please refer to the H. Cross method.

This method applies to mesh systems; the iterative calculation leads to lower actual pressure drops (approx. 50%) in relation to the simplified method.

359 domestic manifolds

Construction Details

Patented anti-block cartridge

The special patented cartridge designed used in 359 series manifolds makes it possible to achieve a high level of operating reliability over time, thanks to the dual sealing gasket system.

The materials used to make it offer a low operating torque during opening/closing procedures, and to minimise the blockage problems linked to limescale, typically present, when ball valves are used.

If necessary, the cartridge can be replaced simply by removing it from the front of the manifold and inserting a new one.

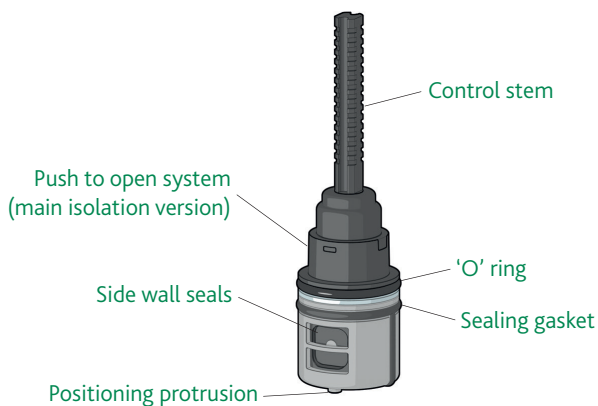

There are two types of cartridge, one used in manifolds with individual isolation valves and one designed for versions with main isolation valves.

The version used in main isolation valves features a stem with a push-to-open system. It helps to achieve the concealed effect for the knobs used to move the cartridge.

Individual isolation cartridge

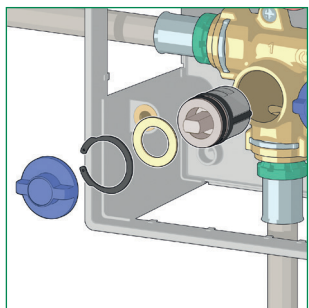

Main isolation cartridge

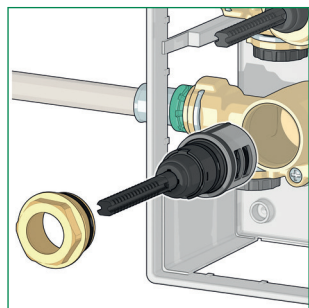

Dezincification resistant material with very low lead content (Low Lead)

Altecnic 359 manifolds are also available in a version made using material with a very low lead content. This material is perfectly in line with the new regulatory provisions concerning contact with potable water.

This is an innovative alloy with a very low lead content (< 0.1 %) and dezincification resistant properties.



Fixing clip coupling

All connections to the manifold are performed by means of a fixing clip system. This offers optimal installation speed and impeccable seal reliability.

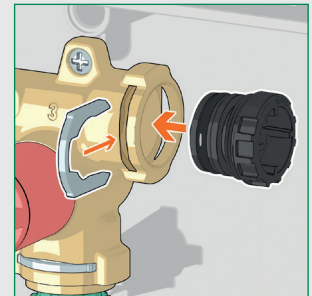

The special connection system does not allow installation errors. The fixing clip only fits into the corresponding groove if the element to be connected is in the correct position.

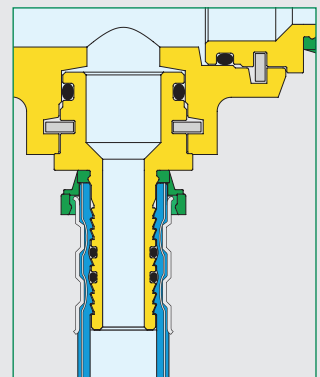

Types of fitting for pipe connection

Pipe connection is extremely easy and takes place by means of a fixing clip system.

Two types of fitting are available: compression or press type. Compression fittings can only be used in inspect-able boxes, while press fittings - given their securing method - can also be used in wall installations.

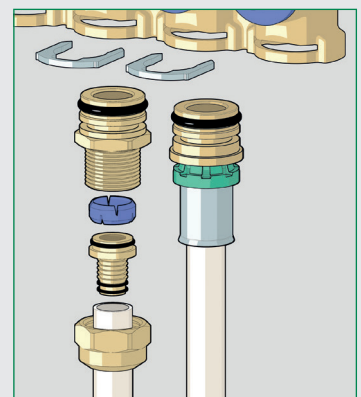

Tee with fixing clip

The tee is an optional accessory capable of assuming different functions depending on the type of manifold/unit to which it is applied. In versions with individual isolation valves, it can be used as an outlet for connection of the recirculation circuit, while in versions with main shut-off valves it allows an outlet to be added.

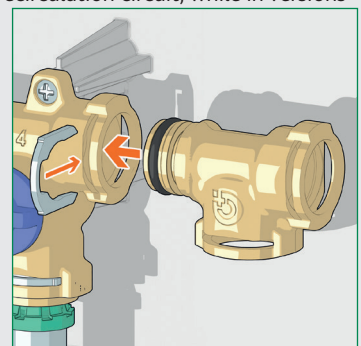

359 domestic manifolds

© Patents & Design Altecnic 2025

Altecnic Ltd retains all rights (including patents, designs and copyrights, trademarks and any other intellectual property rights) in relation to all information provided on or via the website, brochures or any other documents, including all texts, graphics and logos, contained on the website, in brochures or in any other documents published in the name of or on behalf of Altecnic Ltd in any form, without prior written consent of Altecnic Ltd.

Altecnic Ltd Francesco House, Staples Close, Stafford ST16 1WQ

T: +44 (0)1785 218200 E: sales@altecnic.co.uk

Registered in England No: 02095101

altecnic.co.uk

AL 392 03-03-25

E & O.E

© Altecnic Limited. 2025

ALTECNIC™

altecnic
CALEFFI group