

SATK102

heat interface unit



Installation Operation & Maintenance Instructions

SAT102 heat interface unit

SATK102



Function

SATK102 Heat Interface Units (HIU) control the domestic hot water generation in an individual apartment within a centralised boiler or district heating system.

Wall mounted unit.

NOTE: Due to the specification ordered, or the country of destination, the actual unit may differ from those shown.

Content

Function and product range	1
Safety instructions	1
Technical specification	2
Dimensions and components	3
Installation	4
Filling the primary heating system	4
System start up	4
Energy meter installation	5
Electronic controller	5
Dip switch settings	5
Safety and alarms	6
Maintenance	7
Electric connections	9
Trouble shooting and solution	10

Product Range

- SATK10253** 40 kW plate heater exchanger.
- SATK10203** 40 kW plate heater exchanger and primary pump.
- SATK10203HE** 40 kW plate heater exchanger and high efficiency primary pump.
- SATK10254** 70 kW plate heater exchanger.
- SATK10204** 70 kW plate heater exchanger and primary pump.
- SATK10204HE** 70 kW plate heater exchanger and high efficiency primary pump.
- SATK10255** 80 kW plate heater exchanger.
- SATK10205** 80 kW plate heater exchanger and primary pump.
- SATK10203HE** 80 kW plate heater exchanger and high efficiency primary pump.

Safety Instructions

WARNING These instructions must be read and understood before installing and maintaining the HIU.



CAUTION! FAILURE TO FOLLOW THESE INSTRUCTIONS COULD RESULT IN A SAFETY HAZARD!

- The device must be installed, commissioned and maintained by qualified technical personnel in accordance with national regulations and/or relevant local requirements.
- If the device is not installed, commissioned and maintained correctly in accordance with the instructions provided in this manual, it may not work correctly and may endanger the user.
- Flush the pipework thoroughly before installing the HIU to remove any particles, rust, incrustations, limescale, welding slag and any other contaminants. The water circuits must be clean and free from debris.
- Make sure that all connection fittings are watertight.
- When connecting water pipes, make sure that threaded connections are not mechanically overstressed. Over time this may result in breakage, causing water damage and/or personal injury.
- Water temperatures higher than 50°C may cause severe burns. When installing, commissioning and maintaining the device, take the necessary precautions so that these temperatures will not be hazardous for people.
- In the case of particularly hard or impure water, there must be suitable provision for filtering and treating the water before it enters the device, in accordance with current legislation. Failure to do so may result the HIU becoming damaged or working incorrectly.
- Any use of the HIU other than it's intended use is prohibited

Safety Instructions

- 9 Any coupling of the device with other system components must be made while taking the operational characteristics of both units into consideration.
- 10 An incorrect coupling could compromise the operation of the device and/or system.
- 11 If the system is prone to 'water hammer' a water hammer arrester must be installed.
- 12 If hot water recirculation is present or a non-return valve is installed in the cold water inlet, provision must be made to accommodate water expansion by fitting an expansion vessel.

NOTE: Risk of electric shock. Live parts. Shut off the electric supply before opening the HIU cover.

- 1 During installation and maintenance operations, always avoid direct contact with live or potentially hazardous parts.
- 2 The device must not be exposed to water drops or humidity, direct sunlight, the elements, heat sources or high intensity electromagnetic fields.
This device cannot be used in areas at risk of explosion or fire.
- 3 The device must be connected to an independent bipolar switch. If work has to be done on the device, switch off the electric supply first. Do not use devices with automatic or time reset, or which may be reset accidentally.
- 4 Use suitable automatic protection devices in compliance with current legislation.
- 5 The device must always be earthed before it is connected to the electric supply. If the device has to be removed, always disconnect the earth connection after disconnecting the electric supply. Check that the earth connection has been made to the highest of standards under current legislation.
- 6 Electrical installation must only be carried out by a qualified technician, in accordance with current requirements.

General Information

- Please leave the manual as a reference guide for the user.
- Dispose of any packaging in an appropriate manner, most of which can be recycled.
- In this Installation, Operation and Maintenance guide we have endeavoured to make the information as accurate as possible.

We cannot accept any responsibility should it be found that in any respect the information is inaccurate or incomplete or becomes so as a result of further developments or changes to the products.

Key to Symbols

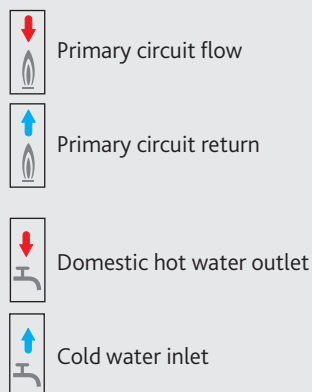

Technical Specification

Medium:	Water
Max. percentage of glycol:	30%
Max. temperature:	85°C
Max. static working pressure:	Primary: 10 bar Domestic hot water: 10 bar
Primary differential pressure capability:	0.9 bar
Min. flow rate to activate domestic flow sensor:	2.7 l/min ±0.3
Power supply:	230 V (ac) ±10% 50 Hz
Power consumption:	105 W (SATK 102) 75 W (SATK 102...HE)
Protection class:	IP 40
Pump:	UPS 15/60 (SATK 102) UPS2 15/60 (SATK 102...HE)
Actuator:	stepper 24 V
Probes:	NTC 10 kΩ
Material	
Components:	brass BS EN 12165 CW617N
Pipes:	stainless steel
Frame:	galvanised steel
Heat Exchanger:	brazed welded stainless steel

Model	Kv	Power Output	Max DHW flow rate
SATK102...3	1.8	40 kW	18 l/min
SATK102...4	2.3	70 kW	27 l/min
SATK102...5	2.4	80 kW	30 l/min

SAT102 heat interface unit

Dimensions

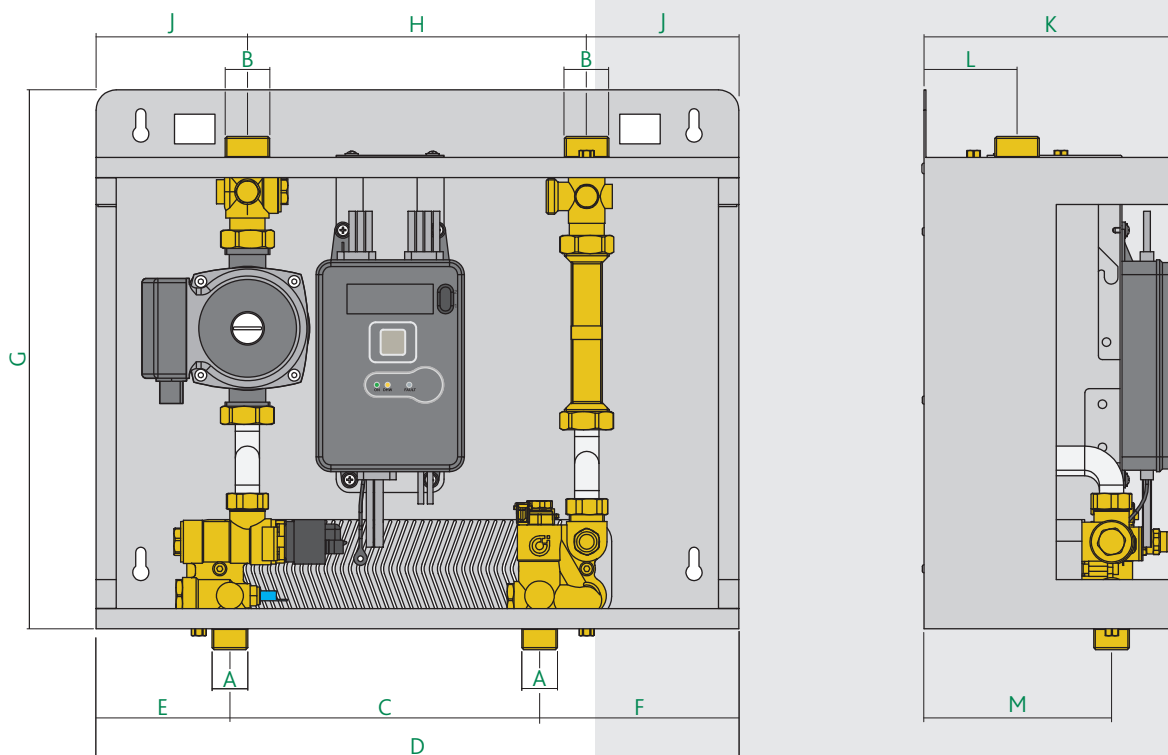

A	B	C	D	E	F	G	H	J	K	L	M
G $\frac{3}{4}$ B	G1B	230	476	99	147	399	252	112	188	69	139

Components

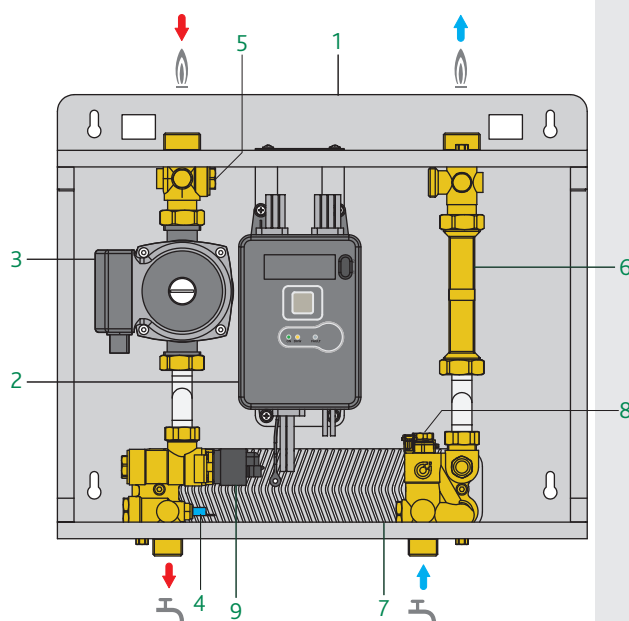

Item	Component
1	Frame
2	Electronic controller
3	Pump (SATK1020X/SATK1020X HE)
4	DHW temperature sensor and strainer
5	Flow temperature pocket probe
6	Energy meter spool piece
7	Plate heat exchanger
8	Flow switch
9	Modulating primary control valve

Installation

The SATK series HIUs are designed for installation in a sheltered domestic environment (or similar), therefore cannot be installed or used outdoors, i.e. in areas directly exposed to atmospheric agents. Outdoor installation may cause malfunctioning and hazards.

If the device is enclosed inside or between cabinets, sufficient space must be provided for routine maintenance procedures. It is recommended that electrical devices are NOT placed underneath the HIU, as they may be damaged in the event of leakage from any hydraulic component of connection.

If this advice is not heeded, the manufacturer cannot be held responsible for any resulting damage.

In the event of a malfunction, fault or incorrect operation, the device should be deactivated; contact a qualified technician for assistance.

NOTE for all models:

If a non-return valve is fitted into the domestic hot water (DHW) cold water inlet, provision MUST be made to accommodate the expansion of the DHW contained within the HIU.

Preparation

After establishing the position where the HIU will be installed, perform the following operations:

- Mark the holes required for securing the HIU to the wall.
- Mark the position of the water pipe connections.

Check the measurements again before installing pipework and electrical cables.

Hydraulic connections:

- 1 connection to the pipework from the centralised boiler plant
- 2 domestic water circuit connection

Electrical:

- 1 electric supply line 230 V (ac) – 50 Hz
- 2 time clock/thermostat line (potential-free)
- 3 centralised bus line for heat meter data transmission (if required)
- 4 centralised electric supply line for heat meter (if required)

The whole system should be thoroughly flushed to remove any debris that may be in the supply pipework to the HIU and to the domestic hot water pipework in the apartment before connecting the HIU.

Fix the HIU to the wall

N.B.: the wall anchors (not supplied) can only guarantee effective support if inserted correctly (in accordance with good technical practice) into walls built using solid or semi-solid bricks. If working with walls built using perforated bricks or blocks, mobile dividing panels or any masonry walls other than those indicated, a preliminary static test must be carried out on the support system.

Isolation Valves

Depending on the specification ordered, the HIU may be supplied with a variety of isolation valves. We recommend that all connections are fitted with isolation valves to allow any maintenance work to be carried out.

We would also recommend that the primary system includes a flushing bypass, with an isolation valve, immediately upstream of the HIU, to allow the primary system to be flushed prior to the first operation of the unit.

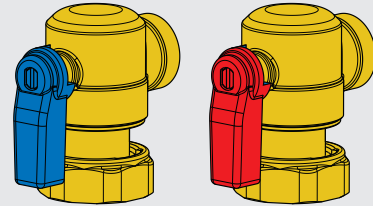

Electrical Connections

Make sure that the electrical system can withstand the maximum power consumption of the appliance, with particular emphasis on the cross-section of the cables.

If in doubt, contact a qualified technician to thoroughly check the electrical system.

Electrical safety of the appliance is only achieved when it is correctly connected to an effective earthing system, constructed as specified in current safety regulations. This is a compulsory safety requirement.

Connection to the main supply

The device is supplied with an electric supply cable - plug not supplied.

The device should be electrically connected to a 230 V (ac) single phase + earth mains supply using the three-wire cable marked with the label as specified below, observing the LIVE (L) - NEUTRAL (N) polarities and the earth connection.

This line must be connected to a circuit breaker device.

Filling the primary heating system

Open the isolation valves on the connections to the centralised boiler plant to fill and pressurise the system to the design pressure.

Once completed, vent the system and check the system pressure again, repeat the filling process if necessary.

System start-up

Before using the HIU, visually check that the hydraulic connections are water tight and the electrical wiring.

After completing the checks, switch on the electricity supply to the HIU and check for the presence of any error signals.

If error signals are indicated, eliminate the fault using the procedure described on page 6.

SAT102 heat interface unit

Energy meter installation

The HIU is designed to include a compact energy meter with integral return probe, with 1" threaded connections and 130 mm overall body length.

Before carrying out any maintenance, repair or part replacement work, proceed as follows:

- turn off the electric supply
- close the isolation valves
- drain the HIU using the drain cocks provided
- remove the spool piece (6)
- remove the blanking plug
- install the flow probe in the ¼" pocket provided (5)
- install the flow meter on the return pipe.

Please refer to the heat meter technical data sheets for further information.

Electronic controller

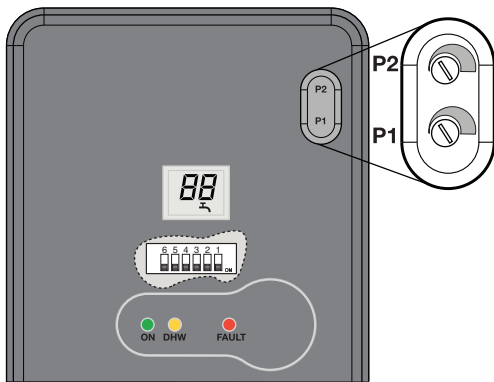

Operating Principle

All functions offered by SATK102 HIUs are controlled by a digital controller.

The controller is factory set with different parameters and settings depending on the model.

There are a number of specific DIP SWITCHES on the controller circuit board; the way these are configured will determine the functions enabled.

Automatic controller function

Reset mixing/modulating valve to zero

Immediately after the power supply has been switched on, the position of the mixing/modulating valve is reset to zero.

Pump anti-clog

When the pump is not in use, it is powered on for a period of 5 seconds every 24 hours.

Mixing valve/modulating valve anti-clog

The anti-clogging cycle for the mixing/modulating valve is run every 24 hours.

User Interface

The user interface, built into the PCB, consists of the following devices.

Indicator LED

The various functions and faults are signalled by either flashing or permanent illumination of the LEDs.

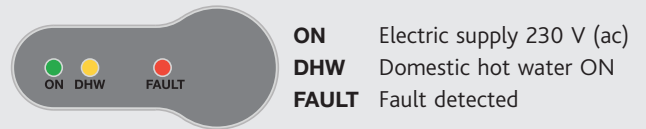

Trimmers for set point settings

These allow the temperature of the domestic hot water cycle to be set and their values will be displayed on the LCD display.



LCD display

The set domestic hot water temperature and error codes are displayed.

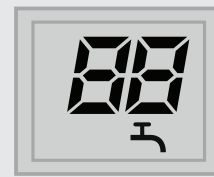

Dip switches

Dip switches allow the setup of the various models and optional functions to be activated.

Default settings:



Light grey: Factory set - do not alter



May be changed to activate optional functions - see page 6

SAT102 heat interface unit

Operating Cycles

Domestic water generation

When the domestic hot water is activated by a water outlet (user's tap) being opened, detected by the domestic water flow meter, the electronic controller regulates the modulating valve opening so as to adjust the temperature detected to the selected set point value.

At the end of the drawing-off procedure, the modulating valve is fully closed.

The active domestic water cycle is signalled by the yellow DHW LED which comes on.

The domestic water temperature can be set using trimmer P1 and is shown on the LCD display.

Optional functions

When activating or de-activating the optional functions the electricity supply must always be turned off.

Domestic water generation

Domestic water preheating function

The function is enabled by setting dip switch 5 to the ON position.

During periods when the domestic water cycle is not used, if the DHW probe detects a temperature 10°C below the SET value, the controller partially opens the domestic water modulating valve for the time required (max. 5 mins) to bring the temperature detected up to a value 5°C below the set point value.

The domestic water preheating function is signalled by the flashing yellow DHW LED.

Safety and alarms

Error codes associated with faults signalled by the lighting up of the FAULT LED are also shown on the display.

Domestic water probe fault

Error code: 6



Removing the fault

Normal operation will be restored once the probe has been replaced.

Incorrect switch setting

Error code: 79

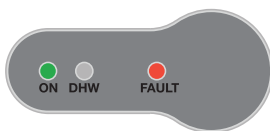

Removing the fault

Restore correct switch setting - see page 5

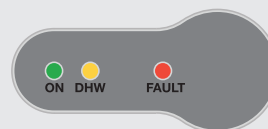
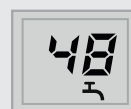
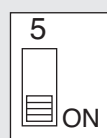
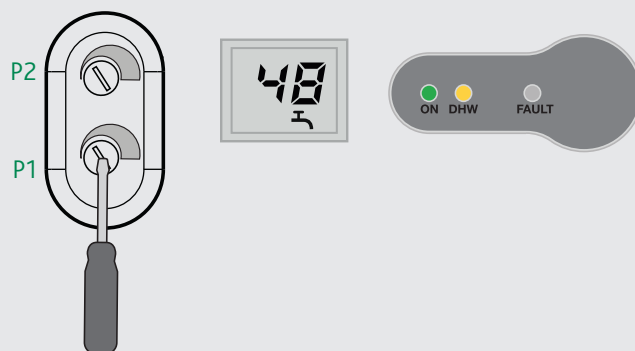

SAT102 heat interface unit

Maintenance

All maintenance procedures should be carried out by an authorised technician.

Regular maintenance guarantees better efficiency and helps to save energy.

Before carrying out any maintenance, repair or part replacement work, proceed as follows:

- Switch off the electricity supply
- Close the isolation valves
- Drain the HIU using the drain cocks provided.

Heat exchanger replacement

- To remove the heat exchanger, loosening the 2 socket head screws holding it in place (A)
- Replace the heat exchanger and the O-rings.
- Re-tighten the 2 fixing screws (A) to a maximum torque of 3Nm.

N.B. The pins fixing the heat exchanger are positioned in such a way as to prevent it being fitted incorrectly.

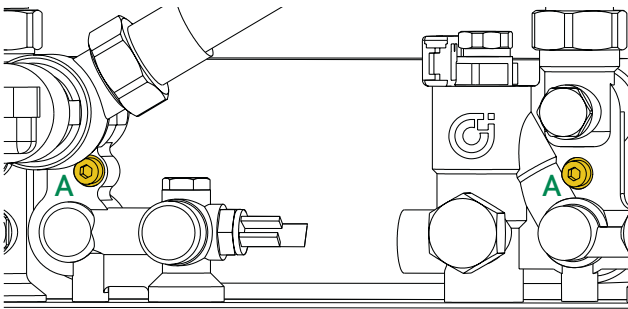

Temperature probe replacement

- Disconnect the probe cable, lightly folding the tab (C) and extracting the connector.
- Unscrew the probe.
- Fit the new probe.
- Re-fit the connector respecting the only possible way it can be inserted.

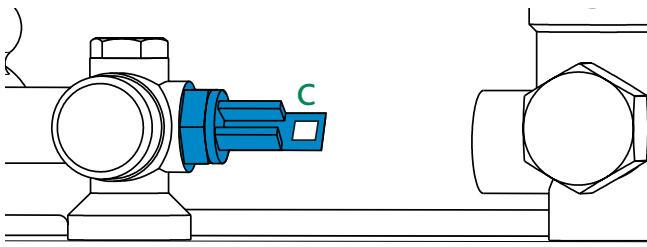

Replacing the valve actuator

- Disconnect the actuator cable, lightly pressing the tab on the connector and extracting it.
- Extract the fixing clip (D) and then the actuator.
- Position the new actuator (E).
- Insert the fixing clip, respecting the correct direction.
- Re-connect the connector.

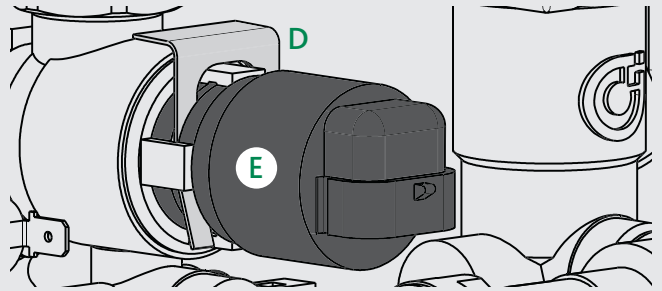

Replacing the valve obturator

- Disconnect the valve actuator - see previous section.
- Unscrewing the lock nut (F) and extract the obturator.
- Replace the obturator and then refit the lock nut (F).
- Insert the fixing clip, respecting the correct direction.
- Re-connect the connector.

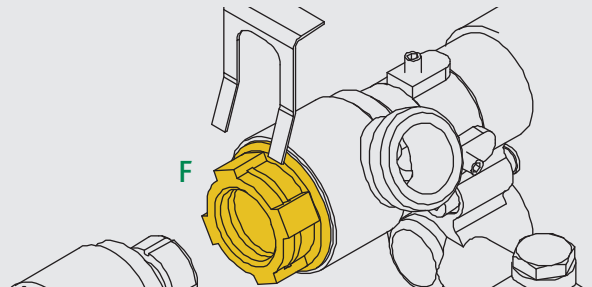

Replacing the DHW priority flow meter

- Disconnect the flow meter cable from the connector.
- Extract the flow sensor (G).
- Position and fit the new sensor.
- Re-connect the cable respecting the only possible way it can be inserted.

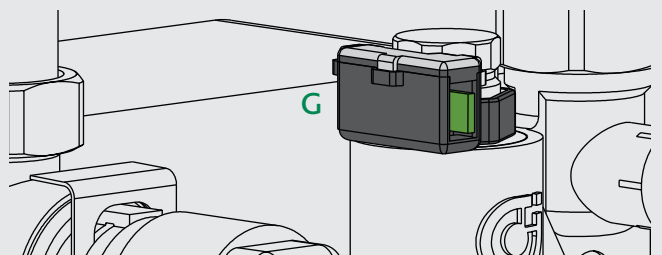

Replacing or cleaning the DHW priority flow meter turbine

- Extract the flow sensor.
- Unscrew and remove the cartridge (H).
- Remove any impurities present or change the cartridge if necessary.
- Screw the cartridge back into position.
- Re-position the flow sensor.

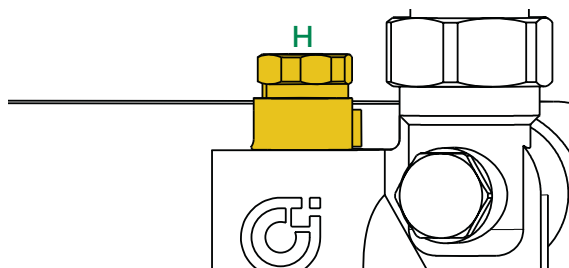

When carrying out maintenance on the electrical part, for the connections follow the diagram on page 8.

After concluding maintenance, proceed with the filling and checking operations described in the chapter "Commissioning" - see page 4.

If you require any information regarding replacement components, please contact Altecnic.

SAT102 heat interface unit

Electrical Wiring

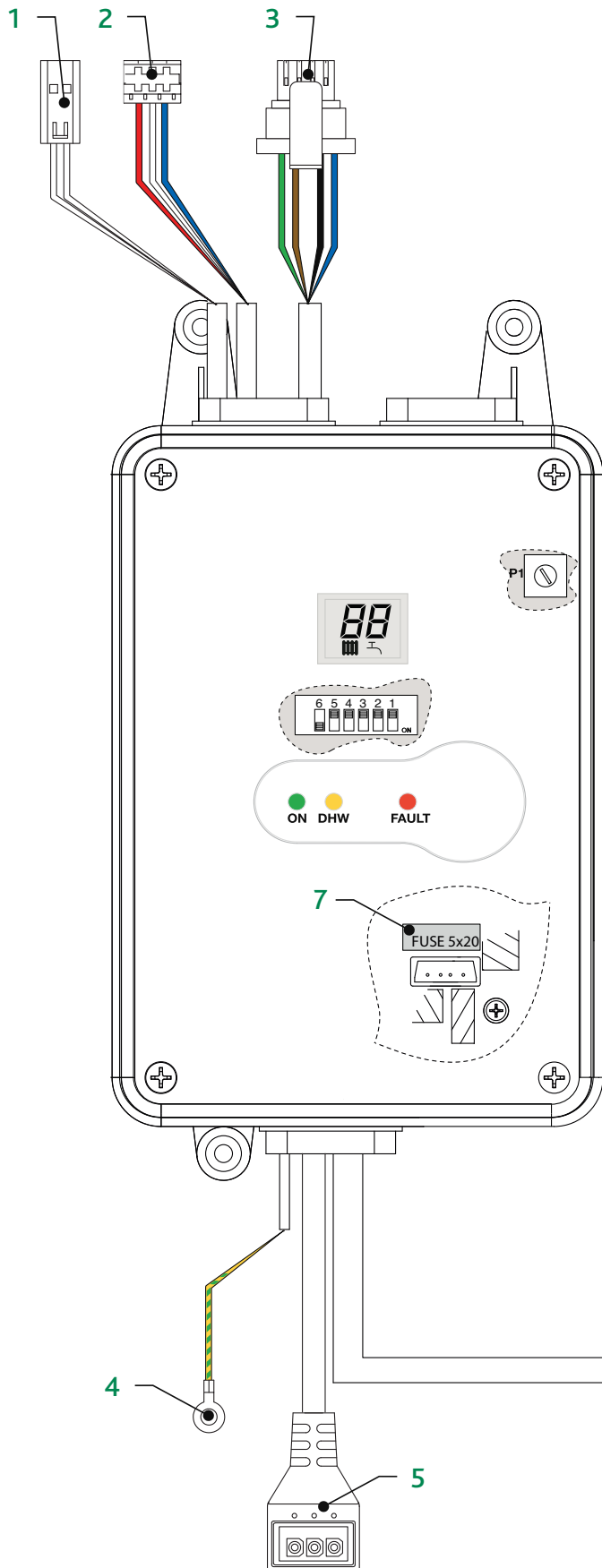

		SATK1025X	SATK100X/HE
1	DHW temperature probe	X	X
2	DHW flow meter	X	X
3	DHW modulating valve actuator	X	X
4	Earth	X	X
5	Pump		X
6	Power Supply 230 V (ac)*	X	X
7	Fuse	X	X

*Wiring to be made during installation

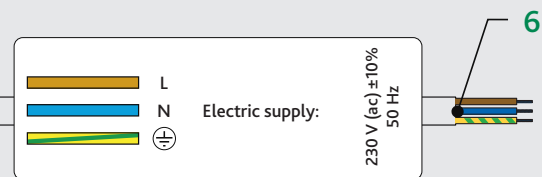

Fault Finding

Fault	Indications	Possible Cause of Fault	Operations to be Performed
The water is not heating	DHW LED on	primary circuit isolating valve closed	open the isolating valve
		modulating valve actuator connector disconnected	re-connect actuator connector
		modulating valve actuator disconnected from valve body	re-connect actuator
		modulating valve actuator faulty	call qualified personnel to have it replaced
		clogged strainer and/or heat exchanger	call qualified personnel to have it replaced
		presence of air in the system	vent the system
		electronic controller not working	call qualified personnel to have it replaced
		valve obturator blocked in closed position	call qualified personnel to have it replaced
		centralised system not working	contact person in charge of system
	FAULT led lit + error code 6 active	DHW temperature probe disconnected	re-connect probe
		DHW temperature probe faulty	call qualified personnel to have it replaced
	FAULT led lit + error code 79 active	incorrect dip switch setting	restore correct switch setting
	DHW Led off	DHW priority flow meter disconnected	re-connect flow meter
		DHW priority flow meter faulty	call qualified personnel to have it replaced
electronic controller not working		call qualified personnel to have it replaced	
all LEDs are off	electricity power supply switched off	switch on electricity supply	
	protection fuse burnt out	call qualified personnel to have it replaced	
	electronic controller not working	call qualified personnel to have it replaced	
The water is hot but does not reach the desired temperature	DHW led on	domestic water cycle temperature set point too low	increase set point
		HIU strainer clogged	call qualified personnel to have it serviced
		exchanger partly clogged	call qualified personnel to have it serviced
		modulating valve actuator faulty	call qualified personnel to have it replaced
		valve obturator blocked in intermediate position	call qualified personnel to have it replaced
		modulating valve actuator connector disconnected	re-connect actuator connector
		excessive demand for DHW	decrease demand
		electronic controller not working	call qualified personnel to have it replaced
		centralised system temperature insufficient	contact person in charge of system
primary circuit flow rate insufficient	contact person in charge of system		
The hot water temperature is too high	DHW led on	domestic water cycle temperature set point too high	decrease set point
		modulating valve actuator faulty	call qualified personnel to have it replaced
		valve obturator blocked in intermediate or open position	call qualified personnel to have it replaced
		electronic controller not working	call qualified personnel to have it replaced
Hot water flow rate is insufficient	DHW led on	HIU strainer clogged	call qualified personnel to have it replaced
		domestic water system shut-off valves partly open	open the valves
		centralised domestic circuit cold water flow rate insufficient	call qualified personnel to have it serviced
The is no hot water flow	DHW led off	possible domestic water system shut-off valves closed	open the valves
		no cold water in centralised domestic circuit	call qualified personnel to have it serviced
		HIU strainer completely clogged	call qualified personnel to have it serviced
		heat exchanger completely blocked	call qualified personnel to have it serviced

SATK102 heat interface unit

Notes:

E & O.E

Altecnic Ltd Mustang Drive, Stafford, Staffordshire ST16 1GW

T: +44 (0)1785 218200 E: sales@altecnic.co.uk

Registered in England No: 2095101

altecnic.co.uk

IOM 069 24-01-15

The logo for Altecnic, featuring the word "altecnic" in a lowercase, sans-serif font. The letter 'a' is stylized with a small green square inside its counter.